

TECHNICAL MANUAL

UNIT MAINTENANCE MANUAL

FOR

**2.75-INCH LOW SPIN, FOLDING FIN AIRCRAFT ROCKETS;
2.75-INCH SPIN STABILIZED,
WRAP AROUND FIN AIRCRAFT ROCKETS;
66MM LIGHT ANTITANK WEAPON SYSTEMS;
3.5-INCH ROCKETS;
AND
M3A2E1 ROCKET MOTOR (JATO)**

DISTRIBUTION STATEMENT A: Approved for public release; distribution is unlimited.

HEADQUARTERS, DEPARTMENT OF THE ARMY

SEPTEMBER 1994

WARNINGS

DO NOT DROP, SLIDE, TUMBLE, OR HANDLE ROCKETS IN ANY MANNER WHICH MIGHT DAMAGE THE MOTOR TUBE AND FINS OR OTHERWISE RENDER THE ROCKET SUSCEPTIBLE TO MALFUNCTION.

DO NOT EXPOSE ROCKETS TO EXTREME, RAPID, AND RECURRENT VARIATIONS IN TEMPERATURE.

TO PREVENT EXPLOSION, DO NOT EXPOSE ROCKETS OR LAUNCHERS LOADED WITH ROCKETS TO THE EXHAUST FROM JET ENGINE STARTER PODS OR GAS TURBINE COMPRESSORS.

ALL UNPACKED (BARE) 2.75-INCH ROCKETS AND ROCKET MOTORS DROPPED FROM ANY HEIGHT WILL BE TURNED IN AS UNSERVICEABLE AMMUNITION.

THE FRONT POST SIGHTS OF THE M72A1 AND M72A2 LAW ROCKETS AND M190 PRACTICE LAUNCHERS CONTAIN SMALL AMOUNTS OF RADIOACTIVE MATERIAL FOR ILLUMINATION. THESE SIGHTS POSE NO SIGNIFICANT HEALTH HAZARD BUT MUST BE PROPERLY CONTROLLED. BROKEN SIGHTS OR INTACT SIGHTS ON EXPENDED LAUNCHERS MUST BE REMOVED PRIOR TO DEMILITARIZATION AND DISPOSED OF AS RADIOACTIVE WASTE IAW AR 385-11.

LIST OF EFFECTIVE PAGES

INSERT LATEST CHANGED PAGES. DESTROY SUPERSEDED PAGES.

NOTE The portion of the text affected by the changes is indicated by a vertical line in the outer margins of the page. Changes to illustrations are indicated by a vertical line adjacent to the identification number.

Dates of issue for original and changed pages are:

Original 0 30 September 1994 Change 1 17 August 2001

TOTAL NUMBER OF PAGES IN THIS PUBLICATION IS 60, CONSISTING OF THE FOLLOWING:

Page	*Change No.
Cover	0
Inside Cover	0
A	1
B	0
i	1
ii thru iv	0
1-1	0
1-2	1
2-1 and 2-2	0
2-3 and 2-4	1
2-4.1 and 2-4.2	1
2-5 and 2-6	0
2-7	1
2-8	0
3-1 thru 3-14	0
3-15 and 3-16	1
3-17 thru 3-24	0
4-1 thru 4-4	0
A-1	1
A-2	0
B-1 thru B-4	0
C-1 and C-2	0
D-1 thru D-4	0

*Zero in this column indicates an original page

THIS PAGE INTENTIONALLY LEFT BLANK

CHANGE)
)
NO. 1)

HEADQUARTERS
DEPARTMENT OF THE ARMY
WASHINGTON, DC, 17 August 2001

UNIT MAINTENANCE MANUAL
FOR
2.75-INCH LOW SPIN, FOLDING FIN AIRCRAFT ROCKETS;
2.75-INCH SPIN STABILIZED,
WRAP AROUND FIN AIRCRAFT ROCKETS;
66MM LIGHT ANTITANK WEAPON SYSTEMS,
3.5-INCH ROCKETS AND M3A2E1 ROCKET MOTOR (JATO)

DISTRIBUTION STATEMENT A: Approved for public release.

TM 9-1340-222-20, 30 September 1994, is changed as follows:

1. File this change sheet in front of the publication for reference purposes.
2. New or changed material is indicated by a vertical bar in the outer margin of the page.
3. Remove old pages and insert new pages as indicated below.

A and B	Aand B
i and ii	i and ii
1-1 and 1-2	1-1 and 1-2
2-3 thru 2-4	2-3 and 2-4
None	2-4.1 and 2-4.2
2-7 and 2-8	2-7 and 2-8
3-15 and 3-16	3-15 and 3-16
A-1 and A-2	A-1 and A-2

By Order of the Secretary of the Army:

ERIC K. SHINSEKI
General, United States Army
Chief of Staff

Official:

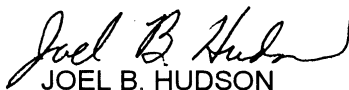

JOEL B. HUDSON

*Administrative Assistant to the
Secretary of the Army*

0120801

DISTRIBUTION: To be distributed in accordance with the initial distribution number (IDN) 400529 requirements for TM 9-1340-222-20.

Technical Manual
No. 9-1340-222-20

HEADQUARTERS
DEPARTMENT OF THE ARMY
Washington, DC, 30 September 1994

**UNIT MAINTENANCE MANUAL
FOR
2.75-INCH LOW SPIN, FOLDING FIN AIRCRAFT ROCKETS;
2.75-INCH SPIN STABILIZED, WRAP AROUND FIN AIRCRAFT ROCKETS;
66MM LIGHT ANTITANK WEAPON SYSTEMS;
3.5-INCH ROCKETS AND M3A2E1 ROCKET MOTOR (JATO)**

REPORTING ERRORS AND RECOMMENDING IMPROVEMENTS

You can help improve this manual. If you find any mistakes or if you know of a way to improve the procedures, please let us know. You may mail, e-mail, or FAX your response. Mail your letter, DA Form 2028 (Recommended Changes to Publications and Blank Forms) or DA Form 2028-2 located in the back of this manual direct to: Commander, U.S. Army TACOM, Armament Research, Development and Engineering Center, ATTN: AMSTA-AR-WEL-S, Picatinny Arsenal, NJ 07806-5000. E-mail address is LSB@PICA.ARMY.MIL. FAX number is Commercial (973) 724-4633, DSN 880-4633. A reply will be furnished to you.

	<u>Page</u>
CHAPTER 1	INTRODUCTION
Section I.	General
1-1.	Scope 1-1
1-2.	Forms, Records and Reports 1-1
Section II.	Safety, Care, and Handling
1-3.	Safety 1-1
1-4.	Care and Handling 1-2
CHAPTER 2	DESCRIPTION AND DATA
Section I.	2.75-Inch Low Spin, Folding Fin Aircraft Rockets (LSFFAR) and Spin Stabilized, Wrap Around Fin Aircraft Rockets (SSWAFAR)
2-1.	Description 2-1
2-2.	Data 2-3
Section II.	66mm Light Antitank Weapon (LAW) System, M72 Series
2-3.	Description 2-5
2-4.	Data 2-5
2-5.	Differences Between Models 2-5
Section III.	3.5-Inch Rockets
2-6.	Description 2-6
2-7.	Data 2-6
Section IV.	Rocket Motor (JATO) M3A2E1
2-8.	Description 2-6
2-9.	Data 2-6
Section V.	Rocket Motors: MK40, MODS 0, 1, 3, and 4; MK66, MODS, 1, 2, 3, and 4 2-7
2-10.	Description 2-7
2-11.	Data 2-7

*This manual supersedes TM 9-1340-222-20 dated 13 June 1973, including all changes.

	Page
CHAPTER 3. MAINTENANCE INSTRUCTIONS	
Section I. Service Upon Receipt of Materiel	
3-1. General	3-1
3-2. Precautions	3-1
3-3. Unpacking Procedures.	3-1
Section II. Tools and Equipment	
3-4. Common Tools and Equipment.	3-3
3-5. Packing Materials, Accessories, and Tools	3-3
Section III. Maintenance	
3-6. General	3-4
3-7. Inspection of Packaging	3-4
3-8. Inspection of Ammunition.	3-6
3-9. Cleaning, Touch Up, and Marking of Ammunition	3-10
3-10. Maintenance of Packaging Hardware	3-10
3-11. Maintenance of Packaging Containers and Materials	3-11
3-12. Marking of Packaging Materials	3-12
3-13. Assembly of 2.75-Inch Rockets	3-12
3-14. Repacking Procedures	3-14
3-15. Color Coding of Boxes With Light Loads	3-23
CHAPTER 4. SHIPMENT AND STORAGE	
Section I. Shipment	
4-1. Precautions	4-1
4-2. Transportation	4-1
Section II. Storage	
4-3. Precautions	4-1
4-4. Storage Data	4-1
4-5. Procedures	4-2
APPENDIX A. REFERENCES	A-1
APPENDIX B. EXPENDABLE AND DURABLE ITEMS LIST	B-1
APPENDIX C. MAINTENANCE ALLOCATION CHART	C-1
APPENDIX D. PACKING MATERIALS, ACCESSORIES, AND TOOLS	D-1

LIST OF ILLUSTRATIONS

<u>Figure</u>	<u>Title</u>	<u>Page</u>
2-1	Typical Complete Round LSFFAR	2-1
2-2	2.75-Inch Rocket Motor MK40 Mod 3 and Mod 4	2-1
2-3	2.75-Inch Rocket Warhead M261 With Nine High Explosive Multipurpose Submunitions or M267 With Three Smoke Signature Practice Submunitions and Six Inert Simulators	2-2
2-4	2.75-Inch Rocket Motor MK66 Mod 1	2-2
2-5	2.75-Inch Rocket With Motor MK66 Mod 1	2-3
2-6	LAW System, Closed.	2-5
2-7	Typical 3.5-Inch Rocket.	2-6
2-8	Rocket Motor M3A2E1	2-6

LIST OF ILLUSTRATIONS - Continued

<u>Figure</u>	<u>Title</u>	<u>Page</u>
3-1	Typical Wirebound Box	3-2
3-2	Sallee Closer	3-2
3-3	Typical Wood Box	3-3
3-4	Torquing Fixture ..	3-13
3-5	Assembly of Fuze to Warhead	3-13
3-6	Procedure for Closing Wirebound Box	3-19
3-7	Packaging of 25 Assembled 2.75-Inch Rockets.....	3-20
3-8	Typical Fiber Container for Warhead and Fuze	3-21
3-9	Metal Shipping Container for Fuzes	3-22
3-10	Shorting Clip ..	3-22

LIST OF TABLES

<u>Figure</u>	<u>Title</u>	<u>Page</u>
2-1	Characteristics of Army Authorized Complete Round LSFFAR and SSWAFAR	2-3
2-2	Characteristics of MK66 and MK40 Rocket Motors	2-8
3-1	Inspection Criteria for Packaging	3-5
3-2	Minimum Safe Distance Between RF and Electric Transmitters and Rocket Storage Areas.....	3-7
3-3	Minimum Safe Distance Between Mobile RF Transmitters and Rocket Storage Areas	3-7
3-4	Minimum Safe Distance Between TV and FM Broadcasting Transmitters and Rocket Storage Areas	3-8
3-5	Inspection Criteria for Rockets	3-8
3-6	Packing, Marking, and Storage Data	3-15
4-1	Quantity-Distance Table for Smoke (WP) Rockets and Warheads (Category A) ...	4-2
4-2	Quantity-Distance Table for Complete Round Rockets and Warheads [Except Smoke(WP)], Rocket Motors and Rocket Weapon Systems (Category F) .	4-3

THIS PAGE INTENTIONALLY LEFT BLANK

**CHAPTER 1
INTRODUCTION
SECTION I. GENERAL**

1-1. SCOPE

a. This is one of a series of technical manuals on servicing and maintenance of rockets, rocket motors (JATOs), and rocket weapon systems. The information in this manual is limited to that required by unit maintenance personnel.

b. The following maintenance manuals are listed:

(1) TM 9-1090-202-12, Aviation Unit Maintenance Manual: Armament Subsystem, Helicopter, 7.62 Millimeter Machine - Gun - 2.75- Inch Rocket Launcher: M21 (Used on UH-1B and UH-1C Helicopters).

(2) TM 9-1090-207-13&P, Operator's, Aviation Unit and Intermediate Maintenance Manual With Repair Parts and Special Tools List Including Depot Maintenance Repair Parts and Special Tools for Rocket Management Subsystem, Inventory - Deployment, XM138.

(3) TM 9-1055-460-13&P, Operator's, Aviation Unit and Intermediate Maintenance Manual (Including Repair Parts and Special Tools List) for HYDRA 70 Rocket Launchers (Formerly 2.75-Inch Rocket Launchers).

c. Destruction procedures are contained in TM 43-0002-33, Destruction of Conventional Ammunition and Improved Conventional Munitions (ICM) to Prevent Enemy Use.

1-2. FORMS, RECORDS, AND REPORTS

a. Authorized Forms. Forms required by unit maintenance personnel are listed in appendix A and in DA Pam 25-30.

b. Report of Accidents. Accidents involving injury to personnel or damage to materiel will be reported on DA Form 285 in accordance with AR 385-40.

c. Report of Damaged or Improper Report of Damaged or Improper Shipment. Materiel received in damaged or otherwise unsatisfactory condition because of deficiencies in preservation, packaging, marking, loading, storage, or handling will be reported on SF 364 in accordance with AR 55-38. Reports of improper shipment or damage caused by transportation discrepancies will be reported on SF 361 in accordance with AR 55-38.

SECTION II. SAFETY, CARE, AND HANDLING

1-3. SAFETY

Precautions generally applicable to ammunition must be observed and all regulations and local standing operating procedures must be followed. Safety rules peculiar to rockets, rocket motors, and rocket weapon systems are discussed below.

a. Rockets which are delivered to the firing line are pointed in the direction that would cause the least damage in case of accidental ignition. Rockets should be stored with warhead pointed nose down, if practical.

b. Some Light Antitank Weapon Systems contain a small amount of radioactive material in the front sight. These systems are identified by the words LIMITED LIGHT SIGHT printed on the launcher and packing containers. No additional storage problems are created by this small amount of radioactive material. When disposing of expended launchers in nontactical situations, however, the front sight should be removed by unscrewing the two screws which secure the sight to the launcher, and the sight assembly must be controlled and disposed of in accordance with AR 385-11.

c. Rocket motors and warheads may include electrical circuits which are susceptible to radio frequency energies and static electricity. Rockets in electrically operated launchers may be susceptible to initiation by electromagnetic radiation.

d. Disassembly of explosive components without specific authorization is strictly prohibited.

1-4. CARE AND HANDLING

a. General.

(1) Explosive materials must be handled with appropriate care at all times.

(2) Boxes containing explosive components must not be dropped, dragged, thrown, tumbled, or otherwise struck. Explosive elements in primers and fuzes are particularly sensitive to heat and shock.

(3) Rockets must not be subject to excessive moisture or prolonged exposure to direct rays of the sun.

(4) Components must be kept in original packing until immediately prior to assembly or preparation for use.

(5) Empty storage containers must be kept from becoming broken or damaged.

(6) Storage procedures outlined in paragraphs 4-3 through 4-5 must be observed.

b. 2.75-Inch Rockets Only.

(1) Crated rockets or rocket motors must be rejected if dropped 5 feet or more on hard surface.

(2) Uncrated rockets or rocket motors must be rejected if dropped from any height.

(3) Fuze-warhead combinations, crated and uncrated, must be rejected if dropped 5 feet or more on hard surface.

(4) Ammunition supply personnel must be contacted for disposition of rejected rockets.

(5) The MK66 rocket motor will not be continuously stored above 140°F for more than 24 hours.

(6) Electrical tests shall not be performed with rockets in launcher. (This will prevent inadvertent rocket firing). The contact arm of the launcher may provide direct electrical path to motor ignition circuit if power source is accidentally applied to contact arm when the launcher is loaded/unloaded. All other possible sources of inadvertent electrical power shall be kept away from the launcher. Ensure electrical equipment, even if turned off and unplugged, is not in the vicinity of a loaded launcher.

(7) For Mod 1 and Mod 3 motors: Avoid contact of any kind, especially metal objects with the contact band of MK 66 rocket motors when loading rockets into launchers on aircraft in a HERO environment. This, along with established procedures and restrictions on the use of the Mod 1 motor, must be followed to minimize exposure to potential HERO environment.

CHAPTER 2
DESCRIPTION AND DATA

SECTION I. 2.75-INCH LOW SPIN, FOLDING FIN AIRCRAFT ROCKETS (LSFFAR)
AND SPIN STABILIZED, WRAP AROUND FIN AIRCRAFT ROCKETS (SSWAFAR)

2-1. DESCRIPTION

The 2.75-inch LSFFARs are air-to-ground rockets (fig. 2-3) designed for deployment from rotary-wing and other low-speed aircraft. Provided with a variety of warheads, 2.75-inch rockets have a wide tactical application with high point-target effectiveness. In addition, the multipurpose submunition (MPSM) warheads are capable of saturating a target area, thus increasing hit probability against discrete target elements. Except for the practice warhead WTU-1/B, which is unfuzed, a complete round 2.75-inch rocket consists of a fuze, a warhead, and a fin-stabilizer rocket motor. The type of warhead with which a round is assembled determines the classification of the complete round (as antipersonnel, high explosive (HE), high explosive antitank (HEAT), MPSM, smoke, flare, or practice). See figures 2-1 through 2-5. The warheads using the MK66 rocket motor are spin stabilized, wrap around fin aircraft rockets.

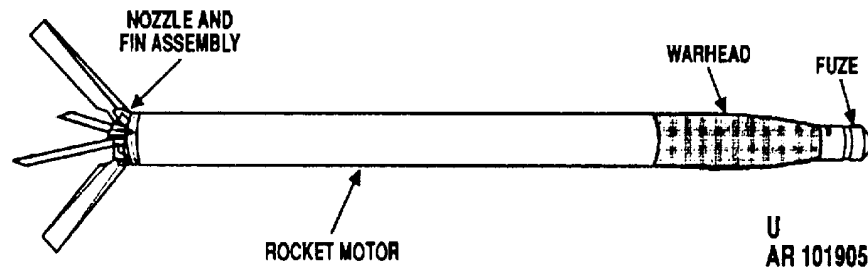

Figure 2-1. Typical Complete Round LSFFAR

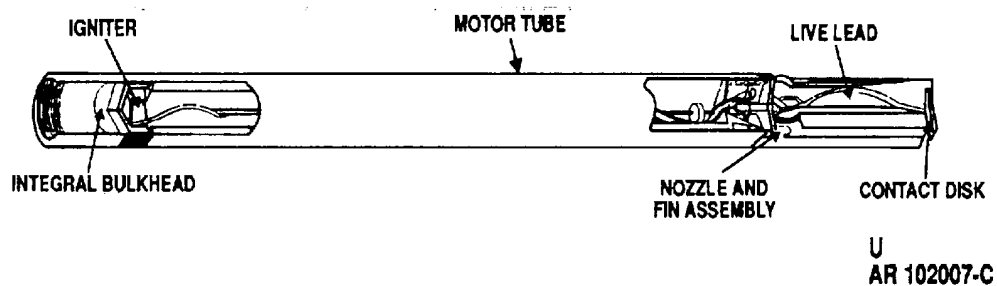

Figure 2-2. 2.75-Inch Rocket Motor MK40 Mod 3 and Mod 4.

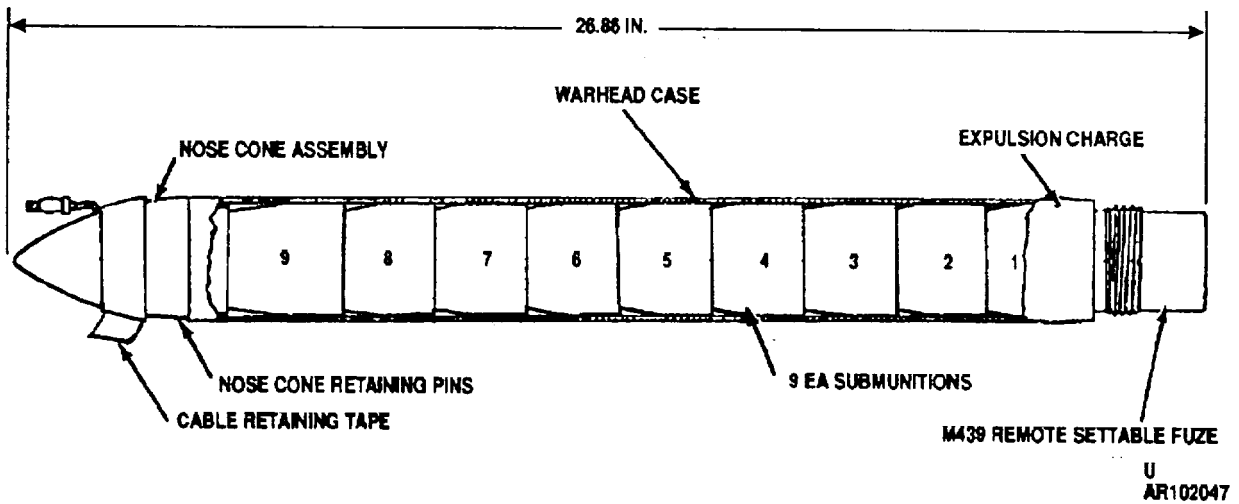

Figure 2-3. 2.75-Inch Rocket Warhead M261 With Nine High Explosive Multipurpose Submunitions or M267 With Three Smoke Signature Practice Submunitions and Six Inert Simulators.

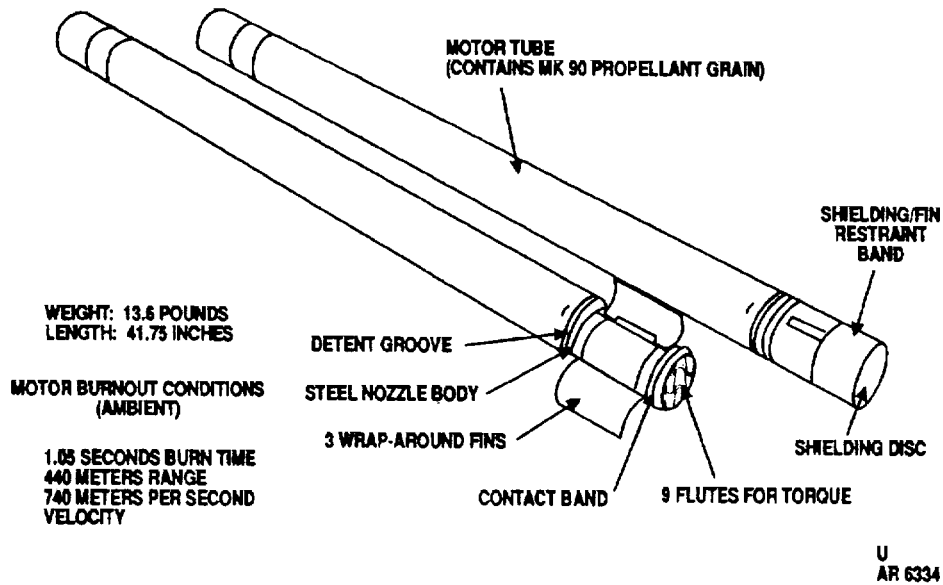
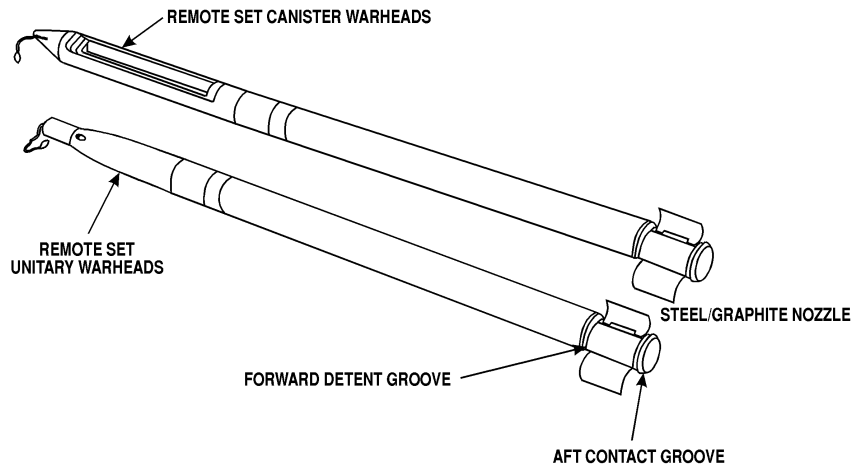

Figure 2-4. 2.75-Inch Rocket Motor MK66 Mod 1.



U
AR 6335

Figure 2-5. 2.75-Inch Rocket With Motor MK66 Mod 1.

2-2. DATA

NOTE

The MK66 (Mods 1, 2, 3, and 4) motors have been type classified standard for use with warheads M261, M267, M151, M229, M257, M264, M255A1, M278, M274, and M264. This is a higher

velocity, longer range motor. The MK40 (Mods 0, 1, 3, and 4) are currently authorized for use with all other warheads. The motors are white with black markings and a brown band.

Characteristics of Army authorized complete round LSFFAR and SSWAFAR are tabulated in table 2-1.

Table 2-1. Characteristics of Army Authorized Complete Round LSFFAR and SSWAFAR

Warhead and fuze	Complete round weight (lb)	Complete round length (in.)	Color coding	DODIC
Flechette, WDU-4A/A w/integral fuze w/motor MK40	20.2	54.6	Olive drab w/white markings and white diamonds	H459
HE, M151 w/fuze M423 w/motor MK40	20.6	52.8	Olive drab w/yellow markings	H490
HE, M151 w/fuze M429 w/motor MK40	20.8	54.7	Olive drab w/yellow markings	H489
HE, M229 w/fuze M423 w/motor MK40	27.9	62.8	Olive drab w/yellow markings	H534
HE, M229 w/fuze M429 w/motor MK40	28.2	64.7	Olive drab w/yellow markings	H488
HEAT, MK5 w/fuze MK181 w/motor MK40	17.6	54.2	Black w/yellow markings	H487
HEDP, M247 w/fuze M438 w/motor MK40	19.8	54.9	Black w/yellow markings	H826
Smoke, WP, M156 w/fuze M423 w/motor MK40	20.6	52.2	Light green w/light red markings and one yellow band	H519
Practice, WTU-1/B w/motor MK40	20.8	52.8	Blue w/white markings	H828

Table 2-1. Characteristics of Army Authorized Complete Round LSFFAR and SSWAFAR - Continued

Warhead and fuze	Complete round weight (lb)	Complete round length (in.)	Color coding	DODIC
Practice, signature, M274 w/motor MK40, Mod 3	20.7	52.7	Blue w/white markings and brown band	H971
Practice, signature, M274 w/motor MK66-1	22.9	55.473	Blue w/white markings and brown band	H972
Practice, signature, M274 w/motor MK66-2	22.9	55.473	Blue w/white markings and brown band	H973
Practice, signature, M274 w/motor MK66-3	22.9	55.473	Blue w/white markings and brown band	H975
Practice, signature, M274 w/motor MK66-4	22.9	55.473	Blue w/white markings and brown band	HA13
Flare, M257 w/fuze M442 w/motor MK40	21.7	67.9	Olive drab w/white markings	H180
Flare, M257 w/fuze M442w/motor MK66-1	24.0	70.975	Olive drab w/white markings	H181
Flare, M257 w/fuze M442 w/motor MK66-2	24.0	70.975	Olive drab w/white markings	H182
Flare, M257 w/fuze M442 w/motor MK66-3	24.0	70.975	Olive drab w/white markings	H183
Smoke, WP, M259 w/fuze M446 w/motor MK40	19.5	63.8	Light green w/red markings and one yellow band	H116
HE, M151 w/fuze M433RS w/motor MK40	21.5	54.0	Olive drab w/yellow markings	H471
HE, M151 w/fuze M440 w/motor MK40	21.7	53.6	Olive drab w/yellow markings	H161
MPSM, M261 w/fuze M439 RC w/motor MK66, Mod 1 or Mod 2	26.9	66.1	Olive drab w/yellow markings and one yellow band	H464
Practice, M267 w/fuze M439 RC MK66, Mod 1 motor	26.9	66.1	Blue w/white markings and brown band	H463
Practice, M267 w/fuze M439 RC w/motor MK66, Mod 2	26.9	66.1	Blue w/white markings and brown band	H463
Practice, M267 w/fuze M439 RC w/motor MK66, Mod 3	26.9	66.1	Blue w/white markings and brown band	H974
Practice, M267 w/fuze M439 RC w/motor MK66, Mod 4	26.9	66.1	Blue w/white markings and brown band	HA17
HE, M151 w/fuze M423 w/motor MK66, Mod 1	23.0	54.6	Olive drab w/yellow markings	H163
HE, M151 w/fuze M423 w/motor MK66, Mod 2	23.0	54.6	Olive drab w/yellow markings	H163
HE, M151 w/fuze M423 w/motor MK66, Mod 3	23.0	54.6	Olive drab w/yellow markings	H583
HE, M151 w/fuze M423 w/motor MK66, Mod 4	23.0	54.6	Olive drab w/yellow markings	HA12
HE, M151 w/fuze M433RS w/motor MK66, Mod 1 or Mod 2	23.1	55.8	Olive drab w/yellow markings	H164
HE, M229 w/fuze M423 w/motor MK66, Mod 2	31.7	65.324	Olive drab w/yellow markings	H642
HE, M229 w/fuze M423 w/motor MK66, Mod 4	31.7	65.324	Olive drab w/yellow markings	HA09
MPSM, M261 w/fuze M439 RC w/motor MK66, Mod 3	26.9	66.1	Olive drab w/yellow markings and one yellow band	H165

Table 2-1. Characteristics of Army Authorized Complete Round LSFFAR and SSWAFAR - Continued

Warhead and fuze	Complete round weight (lb)	Complete round length (in.)	Color coding	DODIC
MPSM, M261 w/fuze M439 RC w/motor MK66, Mod 4	26.9	66.1	Olive drab w/yellow markings and one yellow band	HA14
Smoke, RP, M264 w/fuze M439 w/motor MK66, Mod 3	22.2	66.1	Light green w/black markings and one brown band	H184
Smoke, RP, M264 w/fuze M439 w/motor MK66, Mod 4	22.2	66.1	Light green w/black markings and one brown band	HA15
Flechette, M255A1 w/fuze M439 and motor MK66, Mod 2	27.2	66.178	Olive drab w/white markings and white diamond band	H462
Flechette, M255A1 w/fuze M439 w/motor MK66, Mod 4	27.2	66.1	Olive drab w/white markings and white diamond band	HA11
HE, M151 w/fuze M427 w/motor MK40, Mod 3	20.6	52.8	Olive drab w/yellow markings	H470
HE, M229 w/fuze M427 w/motor MK40, Mod 3	31.7	65.3	Olive drab w/yellow markings	H533
HE, M151 w/fuze M433 w/motor MK66, Mod 3	23.1	55.8	Olive drab w/yellow markings	H582
HE, M229 w/fuze M423 w/motor MK66, Mod 3	31.7	65.324	Olive drab w/yellow markings	H640
HE, M229 w/fuze M423 w/motor MK66, Mod 1	31.7	65.324	Olive drab w/yellow markings	H641
Flare, M278 (IR) w/fuze M442 w/motor MK66, Mod 2	24.4	70.975	Black w/white markings	H154
Flare, M278 (IR) w/fuze M442 w/motor MK66, Mod 4	24.4	70.975	Black w/white markings	HA10

THIS PAGE INTENTIONALLY LEFT BLANK

SECTION II. 66MM LIGHT ANTITANK WEAPON (LAW) SYSTEM, M72 SERIES

2-3. DESCRIPTION

The 66MM Light Antitank Weapon (LAW) system is a lightweight, portable, single-shot weapon used primarily against armored targets, bunkers, and other light field fortifications. As issued, the rocket-launcher unit constitutes the complete weapon system. The rocket launcher, once fired, is considered expendable.

NOTE

In nontactical situations, launchers may be reclaimed for use in training. Contact ammunition supply point for

The M72 Series LAW System (fig. 2-6) consists of three major components: a rocket launcher, a HEAT rocket, and a sling assembly.

a. Rocket Launcher. The tubular rocket launcher is a telescoping, smooth-bore, openbreech weapon. The outer (front) tube is made of plastic-impregnated fiberglass; the inner (rear) tube is made of aluminum. When the launcher is closed, as it is during unit maintenance, the inner (rear) tube and rocket are not visible.

b. Sling Assembly. The sling assembly consists of end cover, webbing, and buckle assemblies.

c. Rocket. The HEAT rocket employed in the LAW system consists of a shaped charge warhead, a point-initiating base-detonating (PIBD) fuze, and a fin-stabilized rocket motor.

2-4. DATA

The following characteristics apply to all currently authorized models of the LAW system:

a. Authorized Models - M72A with coupler (reworked); M72A2 with coupler (reworked); M72A2 with coupler and nozzle wraps (reworked and new production); M72A3 (without coupler and nozzle wraps).

b. Weight (Complete Round) - 5.2 pounds.

c. Color Code (Warhead Only) - Black with yellow markings.

d. DODIC - H557.

2-5. DIFFERENCES BETWEEN MODELS

The 66mm rocket in LAW System M72A2 and M72A3 provides greater target penetration than the M72A1. Otherwise, the systems are essentially identical in performance.

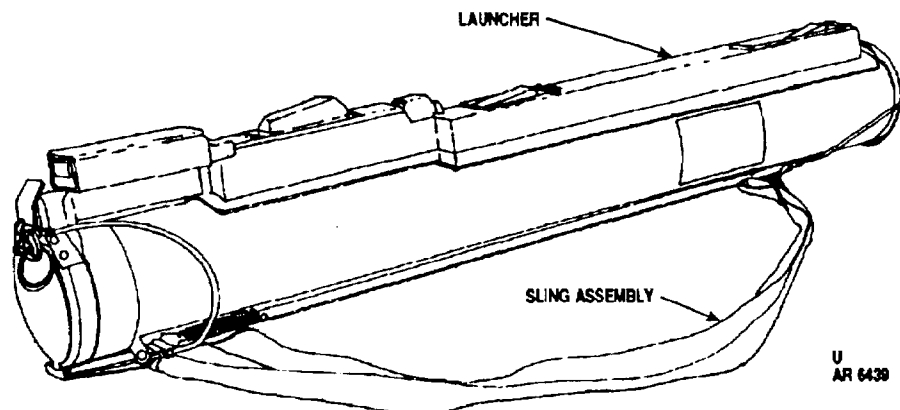

U
AR 6439

Figure 2-6. LAW System, Closed.

SECTION III. 3.5-INCH ROCKETS

2-6. DESCRIPTION

Fin-stabilized 3.5-inch rockets (fig. 2-7) are designed to be fired from reusable 3.5-inch launchers. A complete round rocket consists of a warhead (either HEAT, smoke, or practice), a base-detonating fuze, and an electrically initiated rocket motor. The same model rocketmotor is common to all complete rounds.

2-7. DATA

Characteristics of authorized 3.5-inch rockets are tabulated below:

- a. Authorized Models - M28A2 HEAT; M29A1 and M29A2 Practice; M30 Smoke (WP)
- b. Weight (All Models) - 9 pounds.
- c. Length (All Models) - 23.6 inches.
- d. Color Coding - M28A2, olive drab with yellow markings; M29 series, blue with white markings; M30, gray with yellow markings.
- e. DODIC- M28A2, M600; M29 series, M601; M30, M602.

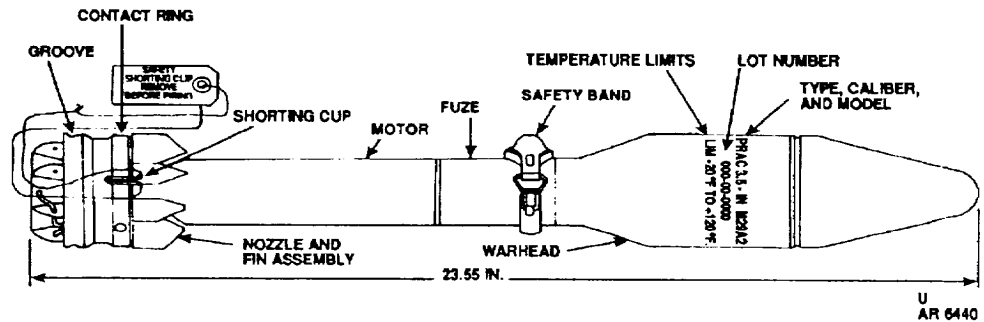

Figure 2-7. Typical 3.5-Inch Rocket.

SECTION IV. ROCKET MOTOR (JATO) M3A2E1

2-8. DESCRIPTION

Rocket Motor M3A2E1 (fig. 2-8) is a solid-propellant thrust unit. It is used primarily for launching target drones from a catapult, although it may be put to other uses requiring similar capability. The rocket motor consists of a body, a nozzle, an igniter assembly, and a propelling charge, and is electrically initiated.

- c. Color Code – Olive drab with yellow markings.
- d. DODIC – H305.

2-9. DATA

The following characteristics apply to the M3A2E1 Rocket Motor:

- a. Weight - 27.1 pounds.
- b. Dimensions - Length, 21.5 inches; diameter, 5.1 inches.

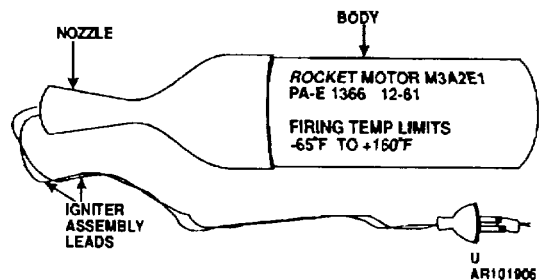

Figure 2-8. Rocket Motor MeA2E1.

SECTION V. ROCKET MOTORS: MK40, MODS 0, 1, 3 AND 4; MK66, MODS 1, 2, 3, AND 4

2-10. DESCRIPTION

a. The MK40 motor (figs. 2-1 and 2-2) was developed by the Naval Weapons Center, China Lake, as a 2.75-inch, unguided air intercept weapon. The motors, with various warheads, are now used extensively as air-to-ground weapons by all U.S. military services.

(1) The motors develop a nominal 720 pounds of thrust for 1.69 seconds and have folding fins for aerodynamic stabilization. The propellant grain which is made of N-5 extruded double-base propellant, externally inhibited with ethyl cellulose, burns outward from the eight point star-shaped center perforation.

(2) The rocket motor consists of a body, a nozzle, an igniter assembly, and a propelling charge, and is electrically initiated.

(3) The MK40 differs from its forerunner, the MK4, in nozzle configuration only. The Mod 0 has a nonintegral bulkhead tube; Mods 1, 3, and 4 have an integral bulkhead. Mods 0 and 1 have the igniter MK125 Mod 4, while Mod 3 has igniter MK125 Mod 5. Mod 4 has igniter MK125 and Mod 6.

b. The MK66 motor (figs. 2-4 and 2-5) Mods 1, 2, 3, and 4 were designed to provide a common 2.75-inch rocket motor for helicopter and high performance aircraft. They utilize a longer motor tube of a different aluminum alloy, a new nozzle, and a fin assembly. The fins are of a spring-loaded,

wrap-around design and are attached around the circumference of the single nozzle. The propellant grain is longer and of a different formulation than the standard grain; however, the grain supports, the igniter, the spacers, etc., are essentially the same as used on the standard MK40 motor. The MK66 motors have a substantially higher thrust (1300 lbs) and a longer range. The MK66 Mods 1, 2, 3, and 4 motors are a nozzle modification of the Mod 0 to increase the spin rate from 4-5.5 rounds per second to 9-10 rounds per second for increased accuracy. Mod 3 is the same as Mod 1 except that it has a radio frequency (RF) filter in the firing circuit to resist inadvertent firing by stray RF currents. The MK66 Mod 2 contains a Hazard Electromagnetic Radiation to Ordnance (HERO) filter (to meet Navy shipboard requirements) which allows it to be handled and stored in electromagnetic radiation environments (making it HERO-SAFE). The MK66 Mod 4 motor is an improvement on the MK66 Mod 2 motor and is tri-service compatible. Changes include a new E³ filtering system located under the contact band, a new initiator, a new igniter, and a new stabilizing rod and attachment assembly. The new ignition mechanism reduces variations in ignition delay time. The bare MK66 Mod 4 motor is considered HERO safe without special precautions. The MK66 Mod 4 motor is also considered safe in Electrostatic Discharge (ESD) environments.

2-11. DATA

Characteristics of MK66 rocket motors and MK40 rocket motors are tabulated in table 2-2.

Table 2-2. Characteristics of MK66 and MK40 Rocket Motors

Item	MK66 motors	MK40 motors
Mods	1, 2, and 3	0, 1, 3, and 4
Length, in.	41.76	39.9
Weight, lb, before firing	13.6	11.4
Nominal shipping, lb	13.6	12.7 (w/fin protector and head support)
Burn time, sec (77° F)	1.10	1.55-1.69
Average thrust, lb (77°F)	1370-1300	750-720
Impulse, lb-sec (77°F)	1500	1150
Motor burnout		
Range, ft	1300	1460
Velocity, fps	2425	1965
Launch spin rate, rps	9-10	1
Launcher exit (64.5 in. tube)		
Velocity, fps	148	112
Acceleration, g		
Initial	60-70	35-40
Final	95-100	40-45
Range-maximum at QE 43° (MPSM warhead), M	8800	8080
Igniter	MK125	MK125
Resistance, ohms	Mod 1 - 0.64-2.5 Mod 2 - 2.2-3.5 Mod 3 - 0.64-2.5	0.63-4.0
Propellant	NOSIH AA-2	MK43 (N-5)
Weight, lb	7	5.9
Temperature limits, FO		
Storage	-50° to + 160°	-50° to +1500
Operation	-500 to + 150°	-500 to + 1500
DODAC	1340-J146 (Mod 1) 1340-J147 (Mod 2) 1340-H309 (Mod 3)	1340-J107 (Mod 0) 1340-J108 (Mod 3)
Packing box		
Weight w/contents, lb	146	131
Dimensions, in.	48-5/8 x 11-7/8 x 9-9/32	46-3/16 x 11-7/8 x 9-9/32
Cube, cu ft	2.9	2.8
Shipping and storage data:		
Quantity-distance class	1.3	1.3
Storage compatibility group	C	C
DOT shipping class	B	B
DOT designation	Rocket Motors, Class B Explosives	
Field storage group	F	F
Drawing number	233AS400	1373658 9220803

a. Color Code - Case is olive drab, white, or blue-gray with a brown band near the head and yellow or black markings.

b. Packing - One motor with propellant grain, coated stabilizer rod, igniter, and fin assembly in a fiber container; six containers per wooden box (when packed separately from the warheads).

CHAPTER 3

MAINTENANCE INSTRUCTIONS

SECTION I. SERVICE UPON RECEIPT OF MATERIEL

3-1. GENERAL

a. Upon receipt of rockets, rocket motors, and rocket weapon systems, each packaged item should be verified against the requisition list. If marking on packaging conflicts with nomenclature on issue document, an error has been made. Ammunition supply point needs to be notified of exact discrepancy.

b. Unless packing boxes show evidence of excessive wetness, obvious damage, or inner pack penetration, do not unpack them until materiel is to be used.

3-2. PRECAUTIONS

a. Cutting and handling metal strapping (bands) can cause injury from sharp edges.

b. The number of rocket fuzes and the amount of flammable liquid at work site should be limited to that necessary for efficient operation.

c. All standard precautions for care and handling of ammunition are applicable to rockets. Paragraph 1-4 outlines specific precautions.

3-3. UNPACKING PROCEDURES

a. Inspection.

(1) Inspect markings (national stock number, nomenclature, and lot number) on packing box/container for legibility. If illegible, open box and note markings on inner pack or rocket and restore illegible numbers.

(2) If box/container is damaged beyond repair, transfer contents to another box/container (para 3-14) and mark appropriately (para 3-12).

(3) Visually inspect each packing box/container for evidence that rockets might have been damaged. Unpack (subparas b., c., d., and e., below) only as far as necessary to determine serviceability of items.

(4) Do not open barrier bags which are obviously undamaged.

NOTE

Save some boxes/containers and packaging materials for immediate reuse. Contact direct support maintenance for disposition of remainder of boxes/containers.

(5) Give priority of issue to any items on which the moisture-proof seal has been broken.

b. Pallets.

WARNING
WEAR GLOVES AND SAFETY
GOGGLES OR FACE SHIELD
WHEN CUTTING BANDING, AND
BE CAREFUL OF BANDING TEN
SION RELEASE.

(1) Cut wire band with metal cutting shears or similar cutting tools.

(2) Remove boxes/containers.

c. Wirebound Boxes(fig. 3-1).

- (1) Cut off wire seals and discard.
- (2) Disengage wire loops with sallee closer (fig. 3-2), screwdriver or pliers, and lift lid panel.
- (3) Remove top layer(s) of packing.
- (4) Lift out bagged fiberboard box.
- (5) Cut open barrier bag along the edge with the most excess material and as close to the seal as possible.
- (6) Open fiberboard box by pulling sealing strip, and remove cushioning material.
- (7) Remove item carefully.

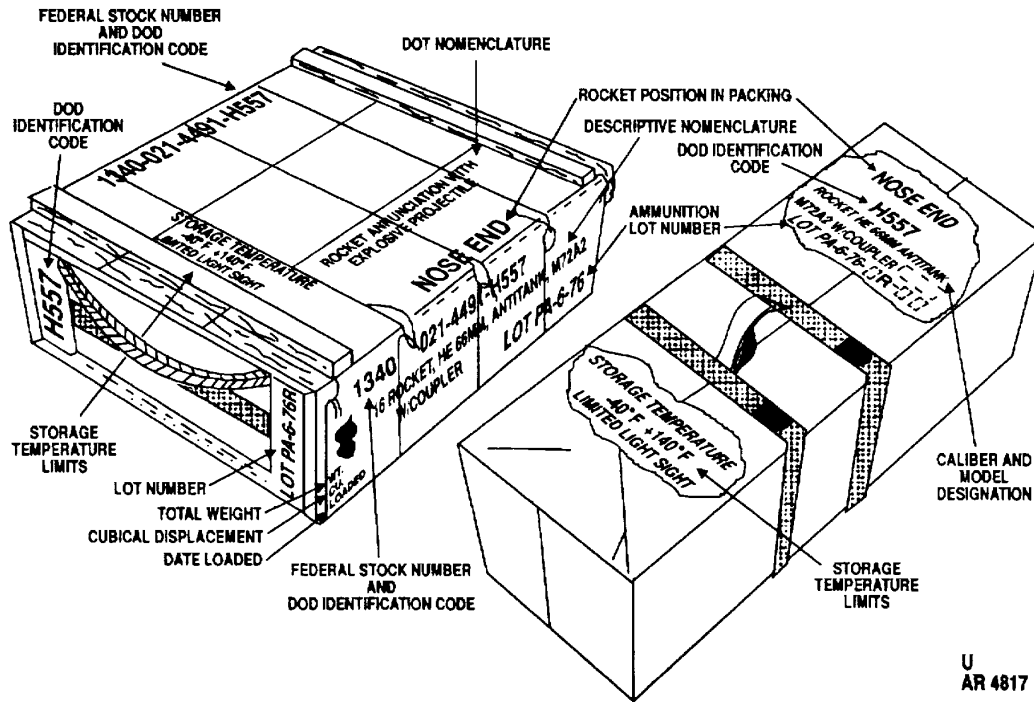

Figure 3-1. Typical Wirebound Box.

Figure 3-1. Typical Wirebound Box.

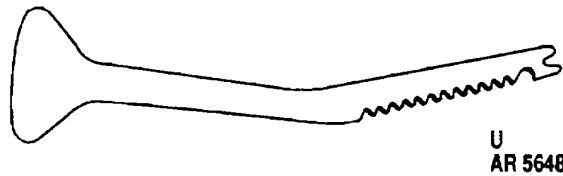

Figure 3-2. Sallee Closer.

d. Wood Boxes (fig. 3-3).**NOTE**

To prevent injury, cut straps on while pressing down on top to release tension.

- (1) Cut steel strapping with metal cutting shears.
- (2) Open box and remove fiber container.
- (3) Remove sealing tape and open fiber container.
- (4) Remove item carefully.

e. Metal Containers for 2.75-Inch Rockets.

- (1) Cut off wire seal and discard.
- (2) Pull 'Y' handle latch and rotate 180°
- (3) Rotate shaft 90°
- (4) Remove cover and let fall (cover is attached to container with wire rope).
- (5) Remove load spreader assembly and retain.
- (6) Grasp rocket fin assembly and remove rocket carefully.
- (7) Replace load spreader assembly.
- (8) Replace cover, rotate 90° and lock "Y" handle latch.

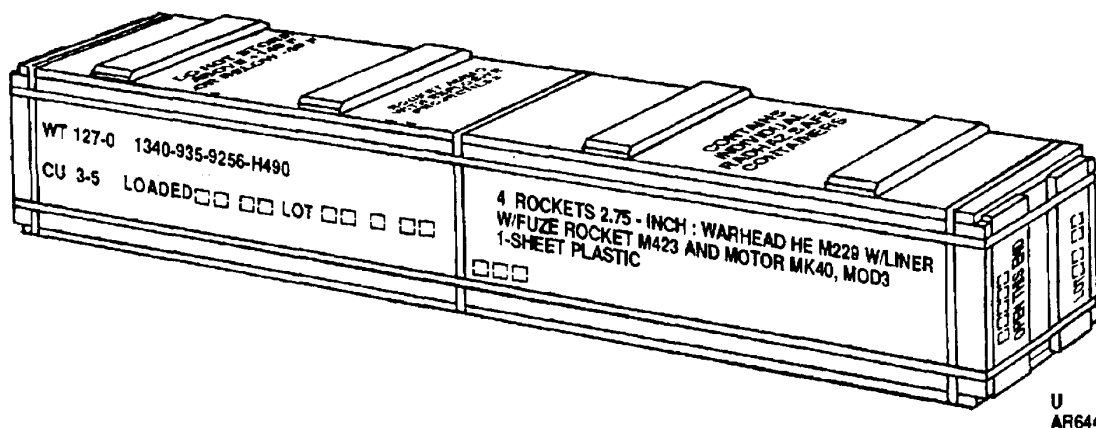

Figure 3-3. Typical Wood Box.

SECTION II. TOOLS AND EQUIPMENT

3-4. COMMON TOOLS AND EQUIPMENT

Standard and commonly used tools and equipment having general application to rockets, rocket motors, and rocket systems are authorized for issue by tables of organization and equipment (TOE).

3-5. PACKING MATERIALS, ACCESSORIES, AND TOOLS -

Packing materials, accessories, and special tools required at unit level are listed in appendix D.

SECTION III. MAINTENANCE

3-6. GENERAL

a. Maintenance at the unit level is performed by designated personnel in using units and is primarily preventive in nature. It is performed to prevent further deterioration of materiel which has been exposed to rough handling or adverse weather conditions. Direct support units may be called upon to provide technical assistance and packing materials for accomplishing maintenance.

b. Responsibilities for maintenance are limited to those functions specified in Appendix C, Maintenance Allocation Chart (MAC).

c. Maintenance will be performed at least 100 feet from any ammunition magazine or storage shelter.

d. Ammunition from packaging should be removed before performing maintenance on packaging materials.

3-7. INSPECTION OF PACKAGING

If initial receipt inspection or periodic storage inspection of packaging reveals damage or deterioration to the extent that serviceability of the ammunition is questionable, unpack ammunition (using procedures in para 3-3), and visually inspect inner packs and/or items. Unpack only as far as necessary to determine serviceability.

a. Packaging Defects. Specific inspection criteria and identification of defects (as acceptable, repairable, or irreparable) are outlined in table 3-1. The most commonly encountered packaging defects are listed below:

(1) Outer containers (boxes) damaged, weathered, or rotted to the extent contents are not protected.

(2) Inner container damaged to the extent contents are not protected or cannot be readily removed.

(3) Container cap or closure insecure to the extent contents are not protected.

(4) Inner containers wet (except metal), rusted, moldy, or mildewed.

(5) Hardware or strapping loose, missing, broken, or ineffective.

(6) Handle or cleat missing or broken.

(7) Contents loose to the extent item may be damaged in handling.

b. Corrective Action.

(1) Replace unserviceable containers using procedures in paragraph 3-14.

(2) Repair broken or damaged boxes using procedures in paragraph 3-11.

(3) Replace banding using procedures in paragraph 3-10.

Table 3-1. Inspection Criteria for Packaging

WOODEN BOXES AND CRATES			
Component	Acceptable	Reparable	Irreparable
Hardware	Operative and tight. Nails, screws, and fasteners present and in good condition.	Inoperative or loose. Nails, screws and fasteners which can be replaced or properly sealed.	None. None.
Ends	Free from damage.	Broken or missing cleats and handles.	Damage which requires disassembly of box.
Wood	Splits less than 3 inches long, no closer than 1 inch to edge of board or adjoining split. The board must be secured by at least one nail on each side of the split when it extends to the end of the board. Warping which does not prevent sealing of box or insertion of required ammunition. Light mold which can be brushed off. Mildew stains which do not affect legibility of markings. Sound tight knots, the diameter of which does not exceed 1/3 the width of the board. Skids securely attached to box or crate. Knots no greater than 1/4 the width of skid.	Splits over 3 inches but no closer than 1 inch to edge of board to adjoining split, or not over 1/8-inch, wide, which can be repaired by use of corrugated fasteners. None. None. None. Loose skids.	Splits closer than 1 inch to edge of board or adjoining split, or over 1/8-inch wide. Warping which prevents insertion or removal rounds and/or sealing of the box. Excessive mildew and mold which cannot be removed and which render markings illegible. Holes or loose knots which exceed 1-1/2 inch largest diameter or 1/3 width of board. Knots greater than 1/4 the width of skid.
Strapping	Present and unweakened by rust or distortion.	Missing, rusted, or distorted.	None.
Wires	Present and intact.	None.	Broken or rusted through.
FIBER CONTAINERS			
Metal ends	Minor rust, cracks, indentations, or splits which do not impair waterproofing or serviceability of container	None.	Perforations, excessive rust, or ends which are crushed or not securely crimped to body.
Body and cap	No tears, cuts, or gouges. No mold, mildew, or rot. Free from wrinkles caused by looseness between layers. Blisters with combined area totaling less than 1/2 square inch. No moisture absorption.	Cuts, tears, or gouges no Cuts, tears, or gouges closer than 1/2 square inch in area, and unpenetrated Layers which can be spot painted. None. None. None. None.	Cuts, tears or gouges closer than 1 inch to closure, more than 1/2 square inch in area, or through all impregnated layers. Moldy, mildewed, or rotted. Wrinkled or peeling. Blisters with combined area of more than 1/2 square inch. Wet or soft containers.

Table 3-1. Inspection Criteria for Packaging - Continued

METAL CONTAINERS			
Component	Acceptable	Reparable	Irreparable
Body	<p>Dents less than ¼-inch deep.</p> <p>Tight seams which prevent entrance of moisture. Free from rust.</p> <p>Free from perforations. Supports which are integral to container present and in serviceable condition.</p>	<p>Dents deeper than ¼ inch which may be removed without weakening structure of container. None.</p> <p>Minor rust which can be removed. None. Supports.</p>	<p>Dents which impair the structural integrity of material.</p> <p>Loose or leaking seams.</p> <p>Rust which has caused pitting and perforation. Perforated. Damaged supports which are integral to container.</p>
Flaps and covers	<p>Free from rust.</p> <p>Free from perforations. Dents which do not prevent cover from closing.</p> <p>Gaskets present and sufficiently serviceable to make container air tight. Operative air test holes and threads.</p>	<p>Minor rust which can be removed. None. Dents which can be removed.</p> <p>Missing or damaged gaskets.</p> <p>None.</p>	<p>Rust which has caused excessive pitting. Perforated. Dents which cannot be removed and/or assembly to body. None.</p> <p>Irreparable air test holes and threads.</p>

METAL BOXES

Body and cover	<p>Free from rust.</p> <p>Tight seams. Dents not exceeding a total of 4 square inches per side, end, or top. Unperforated. Separators integral to container serviceable, allowing easy insertion and removal of contents. Gaskets present and sufficiently serviceable to ensure moisture-proof pack.</p>	<p>Minor rust which can be removed. Repair not practical. Dents exceeding 4 square inches per side, end, or top, or deeper than ¼-inch. None. None.</p> <p>Damaged or missing gaskets.</p>	<p>Extensive pitting and rust. Split seams. Dents which cause creases or folds in metal which cannot be removed.</p> <p>Perforated. Missing or broken separators.</p> <p>Not applicable.</p>
----------------	---	--	--

3-8. INSPECTION OF AMMUNITION

WARNING

- DO NOT EXTEND 66MM LAW LAUNCHER TO OPEN POSITION DURING INSPECTION.

ON LAUNCHERS MARKED *LIMITED LIGHT SIGHT*, THE FRONT POST SIGHTS OF THE M72A1 AND M72A2 LAW ROCKETS AND M190 PRACTICE LAUNCHERS CONTAIN SMALL AMOUNTS OF RADIOACTIVE MATERIALS FOR ILLUMINATION. THESE SIGHTS HEALTH HAZARD BUT MUST BE PROPERLY CONTROLLED. BROKEN SIGHTS OR INTACT SIGHTS ON EXPENDED LAUNCHERS MUST BE REMOVED PRIOR TO DEMILITARIZATION OR DISPOSED OF AS RADIOACTIVE WASTE IN ACCORDANCE WITH AR 385-11. CONDUCT INSPECTIONS ON ELECTRICALLY INITIATED ROCKET MOTORS IN APPROVED AREA COMPLYING WITH HAZARDS OF ELECTROMAGNETIC RADIATION TO ORDNANCE (HERO0 REQUIREMENTS, SPECIFIED IN SUBPARAGRAPH a., BELOW

- DO NOT PERFORM INSPECTION IN EXPOSED AREA DURING RAINY OR WET CONDITIONS OR DURING ELECTRICAL STORMS. EXCEPT DURING ELECTRICAL STORMS, INSPECTION MAY BE PERFORMED INSIDE A BUILDING AT ANY TIME

(3) Inspection and maintenance operation should not be performed within 155 meters of energized power transmission lines.

Table 3-2. Minimum Safe Distance Between RF and Electric Transmitters and Rocket Storage Areas

a. Hazards of Electromagnetic Radiation to Ordnance (HERO) Requirements.

(1) Premature firing of rocket motors by induced current from radio frequency (RF) signal is possible. Tables 3-2 through 3-4 show minimum safe distance in relation to transmitter power.

(2) Lightning is a hazard to all explosives. A strike or nearby miss is almost certain to initiate sensitive explosive elements in rockets.

Transmitter Power (watts)	Minimum safe distances (feet) ³	
	Commercial AM broadcast Transmitters	HF transmitters Other than AM broadcast
10	750	750
0	750	1700
500	750	2400
1,000	750	4800
4,000	850	5500
5,000	1300	7600
10,000	2000	12000
25,000	2800	17000
50,000	3900	24000
100,000	8800	55000
500,000		

¹Present maximum power of U.S. transmitters in commercial AM broadcast frequency range (0.535-to 1.605 MHz).

²Present for international broadcast.

³To convert to meters on this chart: feet x 0.3 = meters.

Table 3-3. Minimum Safe Distance Between Mobile RF Transmitters and Rocket Storage Areas

Transmitter power (watts)	Minimum safe distances (feet) ⁷				
	MF 1.6-to-3.4 MHz industrial	HF 28-to-29.7 MHz amateur	VHF 35-to-36 MHz public use 42-to-44 MHz public use 50-to-54 MHz amateur	VHF 144-to-148 MHz amateur 50.8-to-161.6 MHz public use	UHF 450 to 460 MHz public use
5 ¹					
10	40	100	40	15	10
50	90	220	90	35	20
100	25	310	130	50	30
180 ²				65	40
250	200	490	205	75	45
500 ³			290		
600 ⁴	300	760	315	115	70
1,000	400	980	410	150	90
10,000 ⁵	1250		1300		

¹Citizens band radio (walkie-talkie) (26.96-to-27.23 MHz) - minimum safe distance-five feet.

²Maximum power for 2-way mobile units in VHF (150.8-to-161.6 MHz range) and for 2-way mobile and fixed station units in UHF (450-to-460 MHz range).

³Maximum power for major VHF 2-way mobile and fixed station units in 35-to-44 MHz range.

⁴Maximum power for 2-way fixed station units in VHF (150.8-to-161.6 MHz range).

⁵Maximum power for amateur radio mobile units.

⁶Maximum power for some base stations in 42-to-44 MHz band and 1.6-to-1.8 MHz band. ⁷ To convert feet to meters on this chart: feet x 0.3 = meters.

Table 3-4. Minimum Safe Distance Between TV and FM Broadcasting Transmitters and Rocket Storage Areas

Effective radiative Power (watts)	Minimum safe distances (feet) ⁴		
	Channels 2 to 6 and FM	Channels 7 to 13	UHF
Up to 1,000	1000	750	600
10,000	1800	1300	600
100,000 ¹	3200	2300	1100
316,000 ²	4300	3000	1450
1,000,000	5800	4000	2000
5,000,000 ³	9000	6200	3000
10,000,000	10,200	7400	3500
100,000,000			6000

¹Present maximum power, Channels 2 to 6 and FM.

²Present maximum power, Channels 7 to 13.

³Present maximum power, Channels 14 to 83.

⁴To convert feet to meters on this chart: feet x 0.3 = meters.

b. Material Defects. Specific defects (identified as acceptable, repairable, or irreparable) and inspection criteria are outlined in table 35. The most commonly defects are listed below:

(1) Peeling, blistered, or scratched protective coatings on painted surfaces.

(2) Warhead rust and deterioration.

(3) Corroded Fuze well.

(4) Rust and corrosion on rocket motors.

(5) Cracked or dented metal components.

(6) Missing, illegible, incorrect, or misleading markings.

(7) Mixed types and lots of ammunition (i. e., high explosive with practice, white phosphorus with other smokes, etc.).

Table 3-5. Inspection Criteria for Rockets

66MM LAW

Component	Acceptable	Repairable	Irreparable
Launcher	Firing mechanism, safety devices and components present and undamaged.	None.	Cracked, dented, bowed, loose, or missing firing mechanism, safety devices, or other components.
	Free from cracks.	None.	Cracks in launcher.

2.75-INCH ROCKETS WARHEAD

Body	Free from exudation. Free from cracks. Minor corrosion or metal surfaces.	None. None. Minor corrosion which can be removed with fine sandpaper or steel wool.	Filler exudation. Cracks in warhead. Corrosion which cannot be removed with fine sandpaper or steel wool.
Fuze well	Clean, undamaged threads and free from rust. Light corrosion on liner.	Light rust which can be removed Minor corrosion which can be removed.	Damaged or heavily rusted threads. Extensive corrosion or etching
Paint or protective coating	Minor scratches. Free from blistering and peeling.	Scratches through entire paint layer. - Blistering or peeling in spots.	Deep dents, gouges, or scratches. Blistering or peeling requiring complete repaint.
Marking	Markings legible and correct.	Marking illegible but correct data available for remark	Correct data cannot be determined.

2.75-INCH ROCKET FUZES

Ogive	Minor scratches. Tight assembly. Light corrosion	None. None. None	Dents, gouges, or deep scratches. Loose ogive. Extensive corrosion.
Markings	Markings legible and Correct.	Markings illegible but Correct data available.	Correct data cannot be determined.
Body	Free from corrosion. Free from cracks. Threads undamaged.	None. None. None.	Extensively corroded. Cracks in metal parts. Threads damaged.

Table 3-5. Inspection Criteria for Rockets - Continued

ROCKET MOTORS			
Component	Acceptable	Reparable	Irreparable
Body	Free from cracks. Free from dents. Threads undamaged and free from rust.	None. None. Light rust on threads which can be removed.	Cracks in metal parts. Dents 1/8-inch or more in depth. Damaged or heavily rusted threads.
Paint	Minor scratches.	Scratches through entire paint layer.	Deep scratches requiring complete repaint.
Nozzle and fin assembly	Four fins present and undamaged. Fin hinge pin present. Nozzle seals present. Entire assembly tight. Nozzles tight. Shorting clip present. Live wire intact.	None. None. None. None. None. None.	Missing or damaged fin. Missing fin hinge pin. Missing nozzle seals. Loose assembly. Loose nozzles. Missing shorting clip. Broken lead wire.
ASSEMBLED COMPLETE ROUND ROCKET (Inspect for above defects, plus those listed below.)			
Assembly	Warhead, fuze and motor tightly assembled.	Loosely assembled components which can be tightened.	Assemble components which cannot be tightened or failure of warhead to seat on forward end of rocket motor at any point for full 360°.
3.5-INCH ROCKET			
Warhead	Free from corrosion and scratches. Free from dents and gouges.	None. None.	Deep scratches or corrosion. Dents or gouges.
Fuze	Safety band present and secure. Free from dents and gouges. Free from corrosion	None. None. None.	Missing safety band. Dents or gouges. Corrosion present.
Rocket motor	Free from dents or gouges. Fins undamaged. Shorting clip present. Igniter lead wires present	None. None. None. None.	Dents or gouges. Fins dented or broken. Shorting clip missing. Lead wires missing or broken. and intact.
ROCKET MOTOR M3A2E 1			
Paint	Minor corrosion.	None.	Extensive corrosion.
Markings	Legible and correct.	None.	Illegible or incorrect.
Body	Minor corrosion or scratches. Free from dents and gouges.	None. None.	Extensive corrosion or deep scratches. Dents or gouges.
Nozzle	Tightly assembled. None. Free from dents and gouges. Igniter lead wires present and intact.	None. None. None.	Loose nozzle. Dents or gouges. Missing or broken igniter lead wires.

c. Corrective Action.

(1) Repack acceptable materiel using procedures in paragraph 3-14.

(2) Clean flaked or blistered coating on reparable items and touch up paint and marking following procedures in paragraph 3-9.

(3) Remark following procedures in paragraph 3-9.

d. Disposition of Irreparable Items. For disposition of irreparable ammunition, the next higher maintenance level should be contacted. For disposition of ammunition items considered to be hazardous, Explosive Ordnance Disposal (EOD) personnel should be contacted.
For disposition of irreparable ammunition, the next

3-9. CLEANING, TOUCH UP, AND MARKING OF AMMUNITIONa. Cleaning

(1) Remove dirt, mud and other foreign material using rags or brushes. Use rags dipped in alcohol to remove grease.

(2) Using wire brush, remove flaked, chipped, blistered or peeling paint.

(3) Remove rust using wire brush or sandpaper, and clean with alcohol or acetone dampened cloth.

(4) Clean fuze well and threads with brushes, then rags dipped in alcohol or acetone.

(5) Clean corrosion from aluminum or copper-based metals by first brushing with a wire brush, and then removing residue with rags and corrosion removing compound.

(6) Inspect cleaned item for cracks or other damage or deterioration.

(7) Allow solvent cleaned surfaces to dry thoroughly before painting.

b. Touch up.**NOTE**

Match the original color of paint as closely as possible, using only those paints listed in appendix B.

(1) Use masking tape to cover existing markings which are in good condition and parts, such as fuze threads, which should not be painted

(2) Using a spray can or brush, cover bare metal with primer and allow to dry

(3) Using a spray can or brush, paint primed area with two coats to dry before applying second.

(4) After paint has dried, removed masking tape.

c. Remarking

(1) Observe markings on a like item for correct positioning of data.

(2) Using a felt marker or small brush and paint, restore those markings removed or covered during cleaning and painting and any others requiring touch up. (See tabulated data in chapter 2 for color coding.)

(3) Allow markings to dry before handling or repacking.

(4) Repack as specified in paragraph 3-14.

3-10. MAINTENANCE OF PACKAGING HARDWARE

a. Repairing Damaged Hardware. Hardware which has been damaged to the point that it is inoperable is usually irreparable; however, minor damage can usually be corrected by straightening, as follows:

(1) Using pliers, carefully bend damaged item until its configuration is the same as the serviceable item.

(2) Test repaired hardware for proper functioning.

b. Replacing Irreparable Hardware. Hardware which cannot be repaired can be replaced with a serviceable item cannibalized from an unserviceable container, as follows:

(1) Using a screwdriver remove unserviceable hardware.

(2) Attempt to reinstall serviceable hardware in existing holes. Secure with screws.

(3) If screws are missing or cannot be tightened in existing holes, proceed as follows

- (a) Replace missing screws with others obtained from an unserviceable box.
- (b) If screws cannot be tightened, move hardware (with box top in place) to a different location where screws can be secured. If necessary, carve notch to accommodate hinge pin.
- (c) Mark location for attaching screws and remove hardware.
- (d) Drive and remove a small nail at each location to provide a pilot hole.
- (e) Place hardware and screws in position and secure.

c. Remove rust or Corrosion from Hardware

- (1) brush hardware using wire brush.
- (2) Cover with primer or paint.

d. Replacing Broken, Loose, or Deteriorated Strapping.

- (1) Cut pieces of 5/8-inch banding of sufficient length to go around box plus about 6 to 8 inches.
- (2) Position strap(s) under box.
- (3) Insert one strap end of strap stretcher so that strap is held firmly by stretcher with about 3 inches of strap protruding.
- (4) Place slip over strap end.
- (5) Thread loose end of strap through clip and into stretcher head.
- (6) Tighten strap by repeated movement of ratchet lever until edges begin to cut into box.
- (7) Using banding crimper, crimp clip in two places.
- (8) Release locking pawl on stretcher and slide stretcher out.
- (9) Cut off excess strapping.
- (10) Repeat steps (3) through (9), above, for each strip.

3-11. MAINTENANCE OF PACKING CONTAINERS AND MATERIALS

a. Repairing Cracks and Splits in Wood.

- (1) Hold board tight so that the crack or split is closed.
- (2) Hammer corrugated fasteners into wood at 4- to 6-inch intervals. Fasteners should be centered across crack.

b. Repairing Broken Cleats or Wood Handles

- (1) Remove broken cleat with claw hammer or pry bay.
- (2) Remove serviceable cleats with claw hammer or pry bar from an otherwise unserviceable box.
- (3) Position serviceable cleat on box and secure with three to five small nails.
- (4) Bend nails over inside of box with hammer.

c. Repairing Rope or Strap Handles.

- (1) Remove cleats holding handles with claw hammer or pry bar.
- (2) remove serviceable handle from an otherwise unserviceable box by removing the holding cleats with claw hammer or pry bar.

NOTE

Do not remove nails or staples attaching handles to cleats.

- (3) Position serviceable handle and cleats, and attach to box with three to five nails in each cleat.
- (4) Bend nails over inside of box with hammer.

d. Painting Wood Boxes. Normally, used boxes will not be painted except to obliterate previous markings or to indicate less than full pack (see para 3-15.)

e. Painting Metal Boxes

- (1) Remove dirt, mud, and other foreign material from boxes using wire brush and/or rags dipped in detergent-water solution. Use rags dipped on alcohol to remove grease.
- (2) Using wire brush, remove flaked, chipped, blistered or peeling paint.
- (3) Remove rust and corrosion using a wire brush and sandpaper or rags and corrosion removing compound.
- (4) Dry cleaned surfaces thoroughly.
- (5) If applicable, cover existing markings with masking tape.
- (6) Cover bare metal with primer using spray can or brush, and allow to dry.
- (7) Using spray can or brush, paint primed area with two coats, allowing first coat to dry before applying second.
- (8) Remove masking tape where applied.
- (9) Mark box as required following procedures in paragraph 3-12.

f. Repairing Barrier Bags.

- (1) For bags with surface dampness, suspend bag and allow to dry on all sides.
- (2) For bags with slight surface mildew or fungus wash with soap and water without damaging bag. Wipe

3-12. MARKING OF PACKING MATERIALS

a. Markings on Outer Box. The following information must be legible on each box:

NOTE: Ends of box will have DODIC and lot number. For 2.75-inch rocket metal containers (PA150/151), lot number and DODIC marking are on inside rim of container opening.

<i>Information</i>	<i>Example</i>
Nomenclature	ROCKET, HE, 66MM: ANTITANK, M72A2 (w/coupler)
National stock number (including DODIC)	NSN 1340-01-021-H557
Lot number	LOT PA-6-76
Date of manufacturer	3-71
Quantity	15 (usually precedes nomenclature)

b. Markings on Inner Container. The following information must be legible on each inner container:

<i>Information</i>	<i>Example</i>
Nomenclature	ROCKET, HE, 66MM: ANTITANK, M72A2 (w/coupler)
DODIC	H557
Lot number	LOT PA 6-76
Quantity	5

c. Restoration of Markings.

- (1) Carefully observe information and location of markings on packaging of like item.
- (2) Using waterproof ink marker, china marking pencil or small brush and paint, restore markings which are faded, obliterated during cleaning or painted over.
- (3) Check markings for accuracy and allow to dry.
- (4) Repack ammunition following procedures in paragraph 3-14.

3-13. ASSEMBLY OF 2.75-INCH ROCKETS

The 2.75-inch rockets may be issued as either an assembled or unassembled round, requiring assembly of fuze to a motor/warhead combination, or a total assembly of motor, warhead and fuze. Unit personnel are authorized to replace or assemble rocket components in accordance with the procedures below.

WARNING ENSURE THAT ROCKET MOTOR, HOLDING FIXTURE, AND WORK TABLE ARE GROUND.

NOTE Using torquing fixture illustrated in figure 3-4 for all assembly procedures.

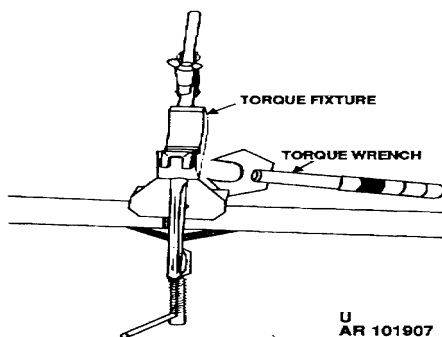

Figure 3-4. Torquing Fixture.

a. Assembly of Fuze to Warhead.

- (1) Position rocket in torquing fixture, as illustrated in figure 3-5.

(1) Position rocket in torquing fixture, as illustrated in figure 3-5.

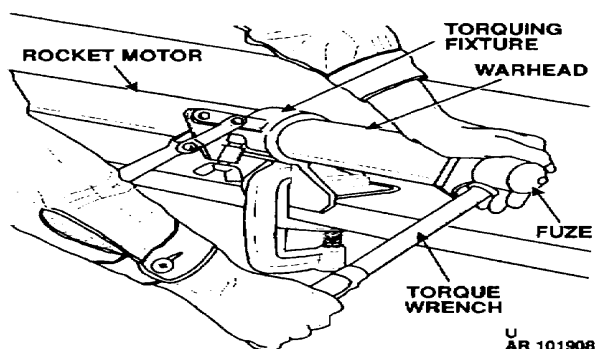

Figure 3-5. Assembly of Fuze to Warhead.

- (2) If replacing an existing fuze, first remove fuze using either a crow's foot attached to socket drive handle, a rocket fuze wrench or a strap wrench, depending on whether or not fuze has slots.

NOTE

Do not use torque wrench for loosening assembled components as calibration may be affected.

- (3) Place replacement fuze in fuze cavity and torque to not less than 55 or more than 75 foot-pounds using torque wrench.

b. Assembly of Warhead (Except WDU-4A1A, M257 and M278) and Fuze to Rocket Motor.

CAUTION

ENSURE THAT TORQUING DEVICE IS PLACED FORWARD OF BROWN BAND ON MOTOR TUBE TO AVOID DAMAGE TO MOTOR CASE.

- (1) Position rocket in torquing fixture (fig. 3-5).
- (2) If replacing an existing warhead, loosen assembled warhead from rocket motor using warhead strap wrench. When warhead is loose, unscrew warhead from motor by hand.
- (3) Remove warhead to be assembled from packing box.
- (4) Assemble warhead to motor, hand tight.

WARNING

FAILURE TO TORQUE WARHEAD PROPERLY MAY RESULT IN LOSS OF WARHEAD ON FIRING OR IN FLIGHT.

- (5) Using torque wrench and crow's foot adapter, torque warhead and motor to not less than 55 or more than 75 foot-pounds.
- (6) Check junction of warhead and motor for gap (i.e., failure of warhead to seat on forward end of motor for a full 360° after specified torque has been applied). If gap exists, notify authorized ammunition supply personnel for disposition.

(7) Assemble fuze to warhead per previous section.

NOTE

If warheads M229 are to be used with paper tube launchers, wrap bourrelet with insulating tape to protect the warhead from the metal case of the launcher and prevent a short in the firing circuit.

c. Assembly of Flechette Warhead WDU A/A and Rocket Motor.

- (1) Position motor in torquing fixture (fig. 3-5).
- (2) Assemble warhead to motor, hand tight.
- (3) Torque warhead and motor to not less than 55 or more than 75 footpounds using warhead strap wrench and torque wrench.
- (4) Check that warhead seats tightly against forward end of motor tube. If gap exists (i.e., if warhead fails to seat on forward end of motor at any point for a full 360° after specified defective component).
- (5) When warheads WDU-4A/A are to be used in launchers LAU-3, apply a inches wide, to the warhead so that the center of the tape is located approximately 7-5/16 inches from the forward end of the warhead. This will protect the warhead from the metal case of the launcher and prevent a short in the rocket motor firing circuit.
- (6) If rockets are installed in launchers LAU-3 at assembly area, performing nose fairing
 - (a) Inspect installed rockets to ensure that insulating tape is properly seated between war-head case and metal case of launcher
 - (b) If tape is improperly seated, remove rocket and retape warhead.

d. Assembly of Flare Warheads M257 and M278 and Rocket Motor.

- (1) Position motor in torquing fixture (fig. 3-4).
- (2) Assemble warhead to motor, hand tight.
- (3) Torque warhead to motor to maximum of 40 foot-pounds using strap wrench and torque wrench. Position strap wrench on warhead "torque here to motor."
- (4) Check that warhead seats tightly against forward end of motor tube. If gap exists (i.e., if warhead fails to seat on forward end of motor at any point for full 360° after specified torque has been applied), notify authorized ammunition personnel for disposition.
- (5) When warheads M257 are to be band of insulating tape, 1- to 2-inches wide, to the warhead so that the center of the tape is located approximately 7-5/16 inches from the forward end of the warhead. This will protect the warhead from the metal case of the launcher, and prevent a short in the rocket motor firing circuit.
- (6) If rockets are installed in launcher LAU-3 at assembly area, perform the following steps prior to installing nose fairing:
 - (a) Inspect installed rockets to ensure that insulating tape is properly seated between war-head case and metal case of launcher.
 - (b) If tape is improperly seated, remove rocket and retape warhead.

3-14. REPACKING PROCEDURES

See table 3-6 for packing and marking data for standard packaging.

Table 3-6. Packing, Marking, and Storage Data

Item	Outer pack	Inner Pack	No. items in outer pack	No. items in inner pack	Total weight (lb)	Total explosive weight (lb)	Cube	Quantity-distance class	Storage compatibility group
Rocket, HE, 66MM, Antitank: M72A1 or M72A2 w/coupler.	Wire-bound	Fiberboard box inside barrier bag	15	1	118	10.1 (octol)	7.1	1.1	E
Rocket, HE, 3.5-Inch, Antitank: M28A2.	Wood	Metal or fiber container	3	1	56	5.7	1.6	1.1	E
Rocket, Practice, 3.5-Inch: M29A1 or M29A2.	Wood	Metal or fiber container	3	1	53		1.6	1.2	C
Rocket, 3.5-Inch, Smoke, WP: M30.	Wood	Metal or fiber container	3	1	54	0.06	1.6	1.2	H
Rocket, 2.75-Inch: w/warhead, WDU-4A/A and rocket motor MK40, Mod 3.	Wood	Fiber container	4	1	162		3.0	1.2	C
Rocket, 2.75-Inch: w/warhead, HE, M151 w/fuze M423 or M429 and rocket motor MK40, Mod 3.	Wood	Fiber container	$\frac{4}{25}$	1	$\frac{127}{776}$	$\frac{9.2}{57.5}$ (comp B4)	$\frac{3.0}{17.3}$	1.1	E
Rocket, 2.75-Inch: w/warhead, HE, M229 w/fuze M423 or M429 and rocket motor MK40, Mod 3.	Wood	Fiber container	$\frac{4}{25}$	1	$\frac{162}{996}$	$\frac{19.2}{120.0}$	$\frac{3.5}{20.1}$	1.1	E
Rocket, 2.75-Inch: w/warhead, HEAT, MK5 w/fuze Mk181 and rocket motor MK40, Mod 3.	Wood	Fiber container	4	1	172	3.6 (comp B4)	3.0	1.1	E
Rocket, 2.75-Inch: w/warhead, HEDP, M247 w/fuze M438 and rocket motor MK40, Mod 3.	Wood	Fiber container	4	1	162	8.0	3.5	1.1	E
Rocket, 2.75-Inch: w/warhead, smoke (WP), M156 w/fuze M423 and rocket motor MK40, Mod 3.	Wood	Fiber container	4	1	162	0.5 (comp B4)	3.5	1.2	H
Rocket, 2.75-Inch: w/warhead, MPSM, M261 w/fuze M439 RC and rocket motor MK66, Mods 1, 2, 3, and 4.	Wood	Fiber container	4	1	162	7.2 (comp B)	3.5	1.1	E
	Metal	Fiber tube/foam	4	1	162			1.2	E
Rocket, 2.75-Inch: w/warhead, practice, M267 w/fuze M439 RC and rocket motor MK66, Mods 1, 2, 3, and 4.	Wood	Fiber container	4	1	162	7.2	3.5	1.3	G
	Metal	Fiber tube/foam	4	1	162			1.2	C
Rocket, 2.75-Inch: w/warhead, HE, M229 w/fuze M423 and rocket motor MK66, Mods 2 and 4	Wood	Fiber container	4	1	162	19.2	3.5	1.1	E
Rocket, 2.75-Inch: w/warhead, practice, M230 w/fuze M435 and rocket motor MK40, Mod 3.	Wood	Fiber container	$\frac{4}{25}$	1	$\frac{127}{776}$		$\frac{3.3}{17.3}$	1.2	F
Rocket, 2.75-Inch: w/warhead, practice, signature, M274.	Wood	Fiber container	4	1	59	70 gr	0.62	1.4	F
Rocket, 2.75-Inch: w/warhead, practice, signature, M274 and rocket motor MK40, Mod 3.	Wood	Fiber container	4	1	127	282 gr	36	1.3	C

Table 3-6. Packing, Marking, and Storage Data - Continued

Item	Outer pack	Inner Pack	No. items in outer pack	No. items per inner pack	Total weight (lb)	Total explosive weight (lb)	Cube	Quantity-distance class	Storage compatibility group
Rocket, 2.75-Inch: w/warhead, practice, signature, M274 and rocket motor MK66, Mods 1, 2, 3, and 4.	Wood	Fiber container	4	1	142	282 gr	37	1.3	C
	Metal	Fiber tube/foam	4	1	147			1.2	C
Fuze, rocket: practice, nose, M435.	Wood	Carton	81	81	70		1.1		
Fuze, rocket: proximity, M429.	Wood	Metal box	20	10	40	180 gr	1.0	1.2	B
Fuze, rocket: point detonating, M423.	Wire-bound	Metal box	24	12	41	216 gr	1.0	1.2	B
Fuze, rocket: remote set, variable time delay, M439 RC.	Wood	Metal box	16	8				1.2	B
Rocket motor (JATO) M3A2E1.	Wood		2		72		1.4	1.3	F
Rocket motor MK40.	Wood	Fiber container	6	1	131		1.3	1.3	C
Rocket motor MK66.	Wood	Fiber container	6	1	142		2.9	1.3	C
Rocket, 2.75-Inch: w/warhead, HE, M151 w/fuze M423 and rocket motor MK66, Mods 1, 2, 3, and 4.	Wood	Fiber container	4	1	137.4	9.2	3.0	1.1	E
	Metal	Fiber tube/foam	4	1	147	9.2		1.1	E
Rocket, 2.75-Inch: w/warhead, HE, M151 w/fuze M433 and rocket motor MK66, Mods 1, 2, 3, and 4.	Metal	Fiber tube/foam	4	1	147	9.2		1.1	E
Rocket, 2.75-Inch: w/warhead, smoke (WP), M259 w/fuze M446 and rocket motor MK40, Mod 3.	Wood	Fiber container	4	1	135		3.5	1.2	H
Rocket, 2.75-Inch: w/warhead, flare, M257 w/fuze M442 w/rocket motor MK40, Mod 3.	Wood	Fiber container	6 (3 warheads, 3 motors; unassembled)	1	131		3	1.2	G
Rocket, 2.75-Inch: w/warhead, flare, M257 w/fuze M442 w/rocket motor MK66, Mods 1, 2, 3, and 4.	Wood	Fiber container	6 (3 warheads, 3 motors; unassembled)	1	132.5		3	1.2	G
Rocket, 2.75-Inch: w/warhead smoke (RP), M264 and rocket motor MK66, Mod 3 and 4.	Metal	Fiber tube	4	1	145	12.12	3.88	1.2	G
Rocket, 2.75-Inch: w/warhead, flechette, M255A1 and rocket motor MK66, Mod 2.	Wood	Fiber container	4	1	138	7.13	3.5	1.2	C
Rocket, 2.75-Inch: w/warhead, flare, M278 and rocket motor MK66, Mod 2.	Wood	Fiber container	6 (3 warheads, 3 motors; unassembled)	1	132.5	5	3	1.3	G

THIS PAGE INTENTIONALLY LEFT BLANK

a. LAW Systems. Pack 15 complete weapon systems per wirebound box, as follows:

- (1) Pack five weapon systems per fiber carton, inserting nose end of weapon in front saddle and opposite end in rear saddle.
- (2) Insert five packed weapon systems in box with front saddle at end of carton marked NOSE END.
- (3) Seal carton with tape.
- (4) Insert cardboard carton in barrier bag. Exhaust air from bag, fold edges over, and seal with tape.
- (5) Attach strap to barrier bag so that package is balanced when lifted.
- (6) Repeat steps (1) through (5), above, until a total of three cartons (15 weapon systems) have been packed. Then continue with step (7), below.
- (7) Place one filler on bottom, one on each side, and one against nose end of wirebound wooden box.
- (8) Pack three bagged cartons weapon systems) in box with nose end of bag coinciding with NOSE END of box.
- 9) Insert cushions between cartons and against each end of box opposite from NOSE END.
- (10) Add fillers as required for a tight pack.
- (11) Place top filler on top.
- (12) Secure cover with five wire loops using Sallee closer, screwdriver, and/or pliers. When using Sallee closer, proceed as follows (fig. 3-6):
 - (a) Insert Sallee closer (A) to engage larger loop. Strike knob to bend down larger loop.
 - (b) Holding top panel down, reinsert closer (B), keeping teeth away from smaller loop until closer is pushed down as far as possible.
 - © When small loop is engaged in teeth of closer, press down and swing handle around, bending small wire loop as far as possible ©.
 - (d) Remove Sallee closer from loop and use knob to tap loop (15 against panel (D)).
 - (e) Repeat until all wire loops are secure.

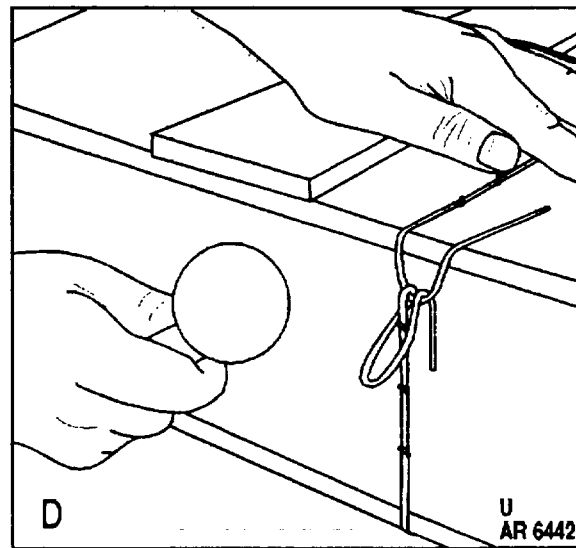
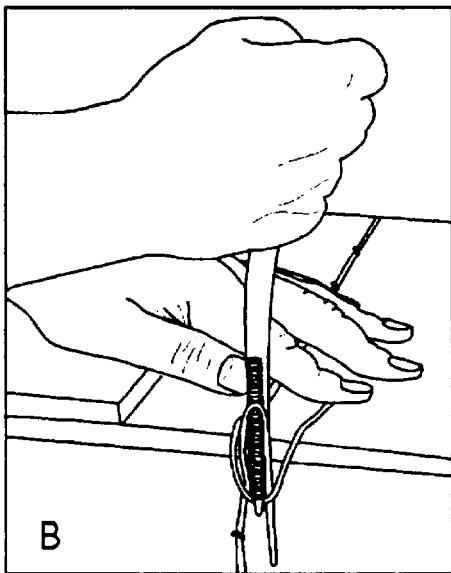
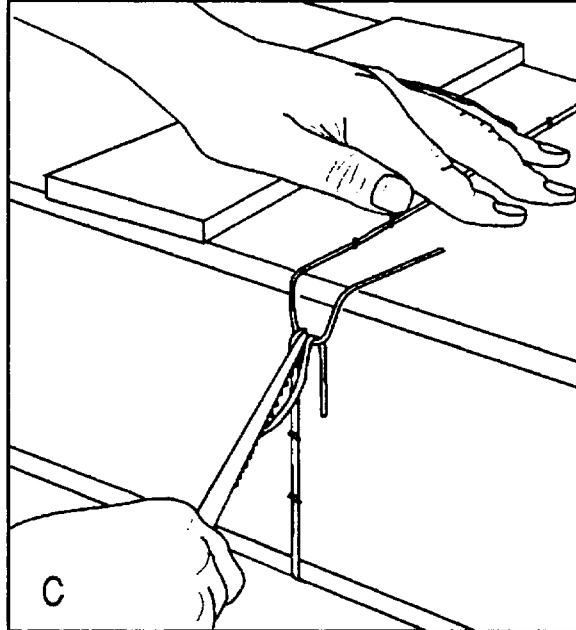
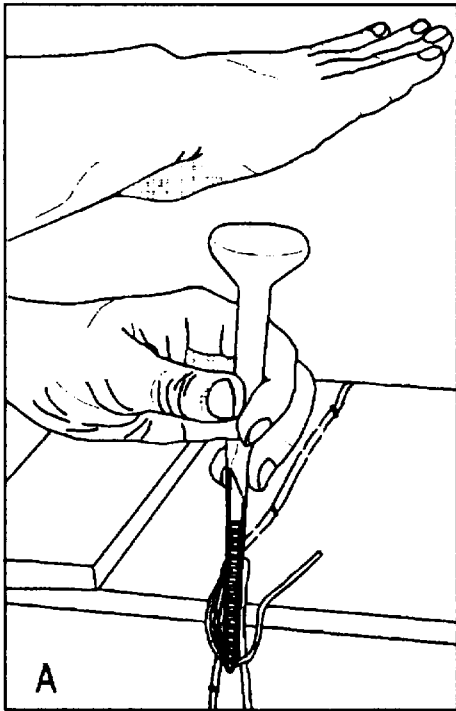

Figure 3-6. Procedure for Closing Wirebound Box.

b. Assembled Complete Round 2.75-Inch Rockets. Except for a repair parts, most 2.75-inch rockets are shipped completely assembled, packed one each per fiber container. Fiber containers are overpacked in wooden boxes in groups of 4 or 25 (fig. 3-7).

- (1) Pack rockets (one each) in fiber containers.
- (2) Arrange fiber containers in fiber layers in wooden box so that sealing strips are located opposite from the NOSE END of the box.

(3) Cover each layer of fiber containers with a sheet of plastic.

(4) Place fillers between layers and at sides, top, and end of box.

(5) Close end panel of box with fasteners or cleats. DO NOT NAIL.

(6) Secure 25-rocket box with two long straps, four short straps and 28 staples; 4-rocket box with two long straps, three short straps, and eight staples.

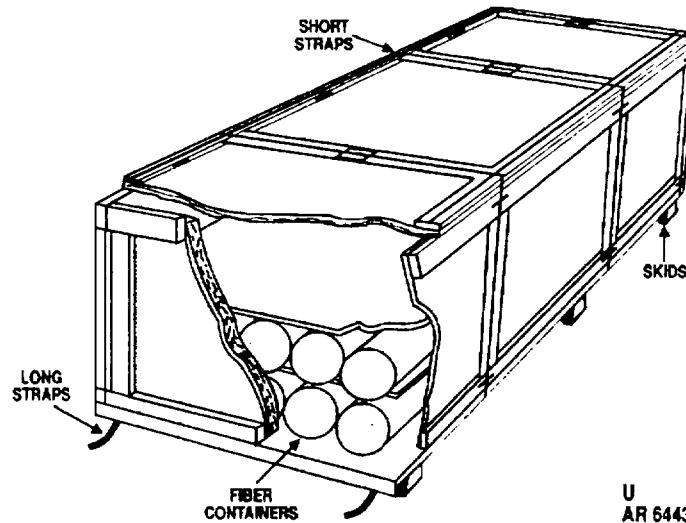

Figure 3-7. Packing Of 25 Assembled 2.75-Inch Rockets.

c. Metal Container, 2.75-Inch Rockets.

Some completely assembled 2.75-inch rockets are packed in metal containers. There are two different containers: the PA150 is for rockets with M261/M267 warheads and MK66 motors, and the PA151 is used for rockets with the M151/M274 warheads and MK66 motors.
 container "Debris".

WARNING

PRIOR TO REPACKING, ENSURE SHIELDING/FIN RESTRAINT BAND IS IN PLACE ON MK66 ROCKMT MOTORS.

- (1) Flip 'Y' handle latch 180° rotate shaft 90°, and remove cover.
- (2) Remove load spreader assembly from cover end of container, if present.
- (7)

(3) Using a flashlight, visually inspect interior of container for debris. If debris is present, remove by using a broom handle, etc. or by facing open end of container down. If debris cannot be removed, replace load spreader assembly, replace cover, and tag or mark the container "Debris".

(4) Slide rocket into one of the four internal fiber tubes, nose end first (on M151/M274 warheads, make sure packing is in place on fuze of warhead), until rocket bottoms out.

(5) Repeat procedure for three remain-

(6) Place load spreader assembly over

Replace cover assembly and lock.

d. 2.75-Inch Warheads. Separately issued warheads (with or without fuzes) are packed one per fiber container (fig. 3-8), for fiber containers per wooden box, as follows:

- (1) Place warheads (one each) in fiber
- (2) Secure fiber containers with tape.
- (3) Return containers to original wooden packing boxes. (Check markings on box for contents and pack accordingly.)
- (4) Close and secure packing boxes.

e. Fuzes for 2.75-Inch Rockets. Pack fuzes into an authorized container (fig. 3-9) using material on hand, as follows:

- (1) Place fuzes in bottom styrene packing in metal containers.
- (2) Place upper styrene packing on top of fuzes and close metal top.
- (3) Wire metal container lids.
- (4) Place containers in wooden boxes and close lid or cover
- (5) Secure box with steel strapping.

f 2.75-Inch Rocket Motors. Separately rocket motors are packed one per fiber container, six fiber containers per wooden box, as follows:

WARNING

PRIOR TO REPACKING, INSTALL SHORTING CLIP (FIG. 3-10) OR MK66 SHIELDING BAND, AS APPLICABLE, ON ALL ROCKETS OR ROCKET MOTORS REMOVED FROM LAUNCHERS.

- (1) Place fin separator assembly on rockets fitted with shorting clips. Place shipping support on rockets fitted with fin protectors.
- (2) Place motor in fiber container, adding as many fillers as necessary to ensure a tight pack.
- (3) Place cover on container and secure with tape.
- (4) Pack fiber containers in wooden box, six containers per box, adding fillers as necessary for a tight fit.
- (5) Secure wood box with wire loops and straps.

g. Shipper-Launcher Containers.

(1) In addition to the packaging described above, rockets may be shipped in shipper-launcher container packages. These containers are issued designed to carry, from manufacture to firing, either 7 or 19 assembled ready-to-fire rockets.

(2) Packing information on shipper-launcher containers is covered in the ate launcher manual.

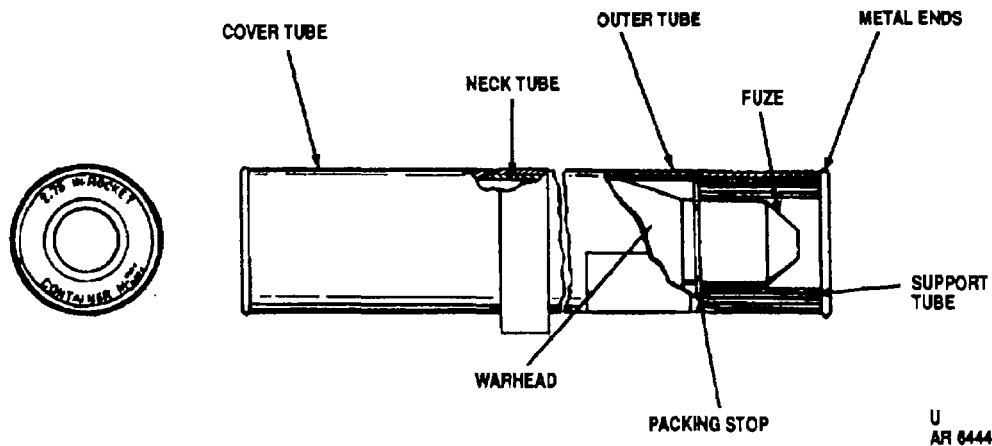

Figure 3-8. Typical Fiber Container for Warhead and Fuze.

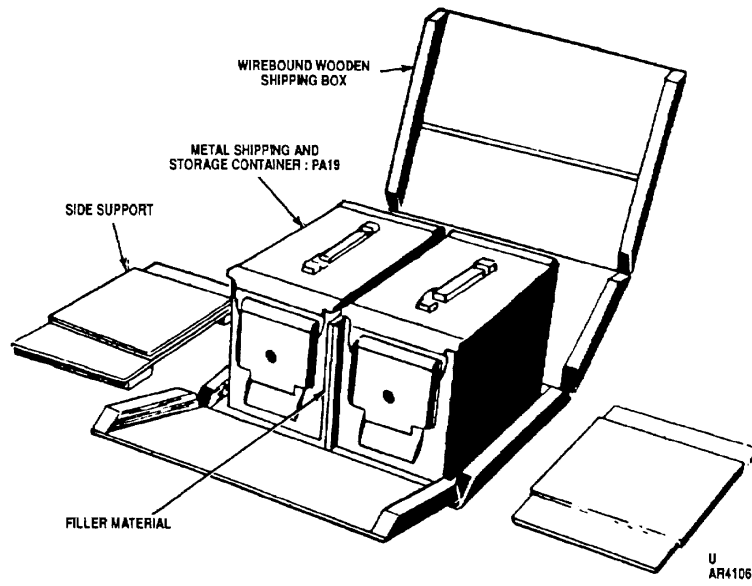

Figure 3-9. Metal Shipping Container for Fuzes.

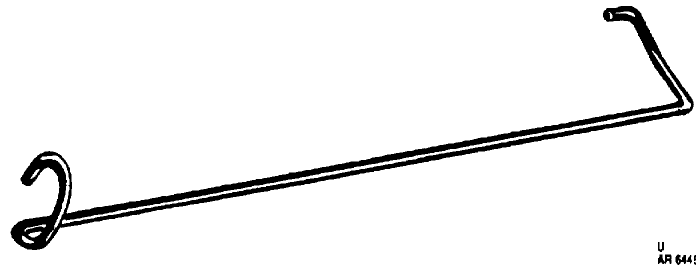

Figure 3-10. Shorting Clip.

3-15. COLOR CODING OF BOXES WITH LIGHT LOADS**NOTE**

Organizations will apply this procedure only when boxes with less than full contents are to be returned to a storage area or transported to a new location. When painting of boxes is required, remarking (except quantity) may be avoided by applying masking tape on markings prior to painting box.

Boxes with less than full contents will be painted orange, as follows:

- a. Check contents with markings on box to verify that nomenclature and lot number are correct.
- b. Make diagram of markings on box and record all markings except quantity figure.
- c. Apply orange enamel to all outer surfaces of box. If enamel is not available, use orange lacquer.
- d. When box is dry, remark box as diagrammed in step b., above.
- e. Count quantity and mark number on box in the same position as the original quantity figure.
- f. Stencil the words LIGHT BOX on each side of box, using approximately the same size letters as original markings

THIS PAGE INTENTIONALLY LEFT BLANK

CHAPTER 4 SHIPMENT AND STORAGE

SECTION I. SHIPMENT

4-1. PRECAUTIONS

Damaged, contaminated or otherwise degraded materiel may be dangerous and/or its usefulness may be impaired.

4-2. TRANSPORTATION

WARNING

DO NOT ROLL, DROP, THROW, OR SUBJECT AMMUNITION TO ROUGH - HANDLING.

- a. Ammunition packages being transported in trucks, jeeps and other tactical vehicles must be blocked and braced. (Blocking and bracing must be adequate to withstand sudden stops and starts, as well as off-road operations.
- b. Ammunition must be stacked in an attitude which prevents shifting.
- c. Packaging must provide adequate protection for ammunition during transportation.

SECTION II. STORAGE

4-3. PRECAUTIONS

- a. Exposure to radio frequency (RF) energies and electromagnetic radiation must be areas. (See tables 3-2 through 3-4.)
- b. Storage site must be selected carefully to avoid exposure to power lines and electric cables.-
- c. Ammunition must not be stored adjacent to reservoirs, water mains or sewer lines.
- d. Level, well drained sites free from readily ignitable and flammable materials must be selected.
- e. Ammunition must not be stored under trees or adjacent to towers or other structures
- f. Nonflammable or fire-resistant overhead covers (e.g., tarpaulin) must be provided for all ammunition. Overhead air space of approximately 18 inches between cover and ammunition must be maintained. Cover must be kept at least 6 inches from pile on ends and at sides to permit circulation of air.
- g. Ammunition containing white phosphorus with warhead must be stored or transported in a vertical position.

4-4. STORAGE DATA

a. Field Storage Categories.

(1) General. Storage categories are the primary groups into which ammunition (including rockets) are segregated for storage in the field. The groupings are based on consideration of the desirability of storing components of complete rounds in adjacent stacks and on consideration of the hazards of propagation of explosion, range of fragments, spread of fires, and contamination. Safety procedures covering storage are based on the following factors:

- (a) Items having comparable storage risks are grouped together in the same category.
- (b) Within each storage category, the maximum quantity of items to be stored within each stack and within each field storage unit (FSU), and the minimum distance between FSU and categories, are specified in quantity-distance tables.

© Normally, only one kind of rocket materiel is stored in a stack. Items should be arranged in stacks in the best manner to facilitate inventory and inspection. Where camouflage is a consideration, stacks may be stepped in toward the top (terraced or pyramid stacking) to decrease shadows. Whenever desirable, components of complete rounds may be stored within the same FSU.

(2) Categories for storage of conventional ammunition. For storage purposes, conventional ammunition is divided into alphabetical categories A through F. White phosphorus-filled rockets fall in category A; all other complete round rockets, rocket motors, and rocket weapon systems fall in category F

b. Quantity-Distance Tables for Field Storage Categories. Procedures set forth in quantity-distance tables 4-1 and 4-2 are to be used as a guide in the storage of rocket materiel in the field only. These procedures are based upon the necessities incident to field storage. It must be emphasized that any reduction of distances or increase in tonnage to those prescribed increases the probability of loss of life and ammunition. Quantity-distance classes, explosive weights, and additional storage and packing data are covered in table 3-6. (See also TM 9-1300-206.)

f.

c. Permanent Installation Storage. For permanent installation storage, the standard quantity-distance classes and the storage compatibility groups given in TM 9-1300-206 apply.

4-5. PROCEDURES

- a. Store rockets in a dry, cool place; never in the direct rays of the sun or where temperatures exceed limits marked on containers.
- b. Locate rockets on one side of the storage area rather than between other types of ammunition and as far away from other ammunition as practicable.
- c. Stack rockets in single rows on tiers. If rockets cannot be pointed nose down, locate stacks where rockets will face a strong natural (or artificial) barrier of not less than 3 feet of sand or earth and in the direction which would offer the least damage in case of accidental detonation. Never point rockets in the direction of another stack of ammunition.
- d. Use heavy, well supported dunnage to prevent stack from sinking and to keep bottom tier off ground.
- e. Use hard stand of gravel and sand rather than excessive dunnage.
- f. Allow at least 6-inch clearance beneath stacks for air circulation.
- g. Dig suitable trenches to prevent water from flowing under pile.

Table 4-1. Quantity-Distance Table for Smoke (WP) Rockets and Warheads (Category A)

Gross tons per stack	Gross tons per FSU	Minimum distance in feet between:			
		Stacks unbaricaded	Stacks barricaded	FSC unbaricaded	Categories
Less than 10	400	40	30	300	750
10-20 max	400	50	40	300	750

Table 4-2. Quantity-Distance Table for Complete Round Rockets and Warheads [Except Smoke (WP)], Rocket Motors and Rocket Weapon Systems (Category F)

Gross tons per stack	Stack barricaded and unbarricaded	Minimum distance in feet between:			
		Gross tons per FSU	FSU unbarricaded	FSU barricaded	Categories
The maximum allowable gross weight per stack will be 20 tons	*	20	200	75	1,500
		30	230	90	1,500
		40	265	99	1,500
		50	295	101	1,500
		60	330	120	1,500
		80	390	135	1,500
		100	455	150	1,500

* The minimum distance between barricaded stacks will be 75 feet. The minimum distance between unbarricaded stacks will be 150 feet.

THIS PAGE INTENTIONALLY LEFT BLANK

APPENDIX A REFERENCES

A-1. Administrative Publications

a. *Publication Indexes.* The following publication index should be consulted frequently for latest changes or revisions of references given in this appendix and for new publications relating to the material covered in this manual.

Consolidated Index of Army Publications and Blank Forms DA PAM 25-30

b. *Army Regulations.*

The Army Radiation Safety Program AR 11-9
 Reporting of Transportation Discrepancies in Shipments AR 55-38
 Accident Reporting and Records AR 385-40
 U.S. Army Explosives Safety Program AR 385-64

c. *DA Pamphlets.*

Ammunition and Explosives Safety Standards DA PAM 385-64

A-2. Blank Forms

Transportation Discrepancy Report SF Form 361
 Report of Discrepancy (ROD) SF Form 364
 US Army Accident Report DA Form 285
 Recommended Changes to Publications and Blank Forms DA Form 2028
 Recommended Changes to Equipment Technical Publications DA Form 2028-2

A-3. Equipment Manuals

Technical Manuals.

Operator's, Aviation Unit and Intermediate Maintenance Manual (Including
 Repair Parts and Special Tools List) for Hydra 70 Rocket Launchers
 (Formerly 2.75-Inch Rocket Launchers TM 9-1055-460-13&P
 Operator's, Aviation Unit and Intermediate Maintenance Manual with Repair
 Parts and Special Tools List Including Depot Maintenance Repair
 Parts and Special Tools for Rocket Management Subsystem
 Inventory Deployment, XM138, Part Number 9324106-002
 (NSN 1090-01-077-8939) TM 9-1090-207-13&P
 Destruction of Conventional Ammunition and Improved Conventional
 Munitions (ICM) to Prevent Enemy Use TM 43-0002-33

THIS PAGE INTENTIONALLY LEFT BLANK

APPENDIX B

EXPENDABLE AND DURABLE ITEMS LIST

SECTION I. INTRODUCTION

B-1. SCOPE

a. This appendix lists expendable and durable items needed to operate and maintain rockets, rocket motors, and rocket weapon systems. This listing is for information only and is not authority to requisition the listed items. These items are authorized to you by CTA 50-970, Expendable Items (except Medical, Class V Repair Parts, and Heraldic items).

b. Expendable and Durable item supplies should be requisitioned through normal supply channels to comply with maintenance requirements.

B-2. EXPIANATION OF COLUMNS

a. Column (1) - Item number. This number is assigned to the entry in the listing for referencing when required.

b. Column (2) - Level. This column identifies the lowest level of maintenance that requires the listed item.

- O - Unit Maintenance
- F - Direct Support Maintenance
- H - General Support Maintenance

c. Column (3) - National Stock Number. This is the national stock number (NSN) assigned to the item; use it to request or requisition the item.

d. Column (4) - Description. Indicates the federal item name and, if required, a description to identify the item. The last line for each item indicates the Commercial and Government Entity Code (CAGEC) in parentheses followed by the part number.

e. Column (5) - Unit of Measure (U/M)/Unit of Issue (U/I). This measure is expressed by a two-character alphabetical abbreviation (e.g., EA, IN, PR). If the unit of measure differs from the unit of issue as shown in the Army Master Data File (AMDF), requisition the lowest unit of issue that will satisfy your requirement.

SECTION II. EXPENDABLE AND DURABLE ITEMS LIST

(1)	(2)	(3)	(4)	(5)
Item Number	Level	National Stock Number	Description	(U/M)/ (U/I)
1	O	6810-00-184-4796	ACETONE, TECHNICAL: 5 gallon can (81348) O-A-51	CN
2	O	6810-00-205-6786	ALCOHOL, DENATURED: Grade IV (81348) O-E-760	QT
3	O	8020-00-240-6361	BRUSH, ARTIST'S: Flat chisel edge, 1/8 in. w. (81348) H-B-118	EA
4	O	8020-00-262-9098	BRUSH, ARTIST'S: (81348) H-B-118	EA
5	O	8020-00-889-7919	BRUSH, PAINT: 1-1/2 in. x 13/32 in. (81348) H-B-420	EA
6	O	8020-00-262-9084	BRUSH, VARNISH: Flat w/ square edge, 1/2 in. w, 1/4 in. thk, 1-1/4 in. lg. (45092) 608-1	EA
7	O	6850-00-174-9672	CORROSION REMOVING COMPOUND: Liquid, type II, 1 gal bottle (81349) MILC10578	GL
8	O	7930-00-249-8036	DETERGENT, GENERAL PURPOSE: Powder, 5 lb container (81348) A-A-1376	CO
9	O	8010-00-297-2122	ENAMEL: Black, No. 37038 (81348) TT-E-516	GL
10	O	8010-00-297-2119	ENAMEL: Blue, No. 35109 (81348) TT-E-516	GL
11	O	8010-00-828-3193	ENAMEL: Green, lusterrless, No. 34558 (81348) TT-E-516	GL
12	O	8010-00-297-2116	ENAMEL: Olive drab, No. 34088, 1 gal. can (81348) TT-E-516	GL
13	O	8010-00-297-2113	ENAMEL: Olive drab, No. 34088, 5 gal. pail (81348) TT-E-516	GL

(1) Item Number	(2) Level	(3) National Stock Number	(4) Description	(5) (U/M)/ (U/I)
14	O	8010-00-088-0096	ENAMEL: Orange, No. 32246, 1 qt. car (81348) TT-E-515	QT
15	O	8010-00-297-2112	ENAMEL: Yellow, No. 33538 (81348) TT-E-516	GL
16	O	8010-00-297-0568	ENAMEL: White, No. 37875 (81348) TT-E-516	GL
17	O	7510-00-161-0815	INK, MARKING, STENCIL: White (58536) A-A-208	GL
18	O	8010-00-582-5382	LACQUER: Black, No. 37038 (83421) 8010-00-582-5382	PT
19	O	8010-00-664-1914	LACQUER: Gray, No. 36231 (81348) TT-L-20	PT
20	O	8010-00-584-3149	LACQUER: Olive drab, No. 14064 (83421) 8010-00-584-3149	PT
21	O	8010-00-721-9479	LACQUER: Orange, No. 12215 (83421) 8010-00-721-9479	PT
22	O	8010-00-584-3148	LACQUER: Orange, No. 12197 (83421) 8010-00-584-3148	PT
23	O	8010-00-721-9744	LACQUER: Yellow, No. 13538 (83421) 8010-00-721-9744	PK
24	O	8010-00-584-3150	LACQUER: White, No. 37875 (87187) 1502	PT
25	O	8010-00-067-5436	LACQUER: Clear (81348) TT-E-00488	PT
26	O	7520-00-973-1059	MARKER, TUBE TYPE: Black, felt chisel tip, pocket clip provided (81348) GG-M-00114	DZ
27	O	7520-00-973-1062	MARKER, TUBE TYPE: Red, felt chisel tip, pocket clip provided (81348) GG-M-00114	DZ
28	O	7520-00-079-0288	MARKER, TUBE TYPE: Yellow, felt chisel tip, pocket clip provided (81348) GG-M-00114	DZ

(1) Item Number	(2) Level	(3) National Stock Number	(4) Description	(5) (U/M)/ (U/I)
29	O	5315-00-889-2745	NAIL, BOX: Style 4A, type I, 2-1/2 in. fastening lg (81348) FF-N-105	PG
30	O	5350-01-289-7469	PAPER, ABRASIVE: Flint (81348) P-P-105	PK
31	O	8010-00-161-7275	PRIMER, COATING: Zinc chromate (96906) MS35612-2	CN
32	O	7920-00-205-1711	RAG, WIPING: Cotton, unbleached, mixture, 50 lb. bale (58536) A-A-2522	BE
33	O	8135-00-281-4071	STRAPPING: Steel, 5/8 in. wide, 0.020 in. thick (81346) ASTM D 3953-87	CL
34	O	8135-00-283-0671	STRAPPING: Steel 1-1/4 in. (81346) ASTM D 3953-87	CL
35	O	7510-00-266-6711	TAPE, PRESSURE, SENSITIVE ADHESIVE: 3/4 in. (52152) 232 3/4 in.	RO
36	O	7510-00-266-6715	TAPE, PRESSURE, SENSITIVE ADHESIVE: 2 in. (52170) 351 2 IN.	RO
37	O	8010-00-160-5788	THINNER, PAINT PRODUCTS: LACQUER, CLEAR (58536) A-A-857	PL
38	O	9505-00-294-7373	WIRE, NONELECTRICAL: Round, zinc coated, .063 in outside dia., medium temper (81346) ASTM A641 (when exhausted use 9505-00-248-9851)	CL
39	O	5350-00-242-4405	WOOL, METALLIC: Type II, class I, 1 lb. roll (58536) A-A-1043	LB

*APPENDIX C**MAINTENANCE ALLOCATION CHART**SECTION I. INTRODUCTION***C-1. GENERAL**

a. The maintenance allocation chart designates responsibility for the performance of maintenance functions.

b. Only the lowest level of maintenance authorized to perform a maintenance function is indicated.

c. A maintenance function assigned a maintenance level will automatically be authorized to be performed at any higher maintenance level.

d. A maintenance function that cannot be performed at the assigned level of maintenance for any reason may be evacuated to the next higher maintenance organization. Higher maintenance levels will perform the maintenance functions of lower maintenance levels when required or directed by the appropriate commander.

C-2. DEFINITIONS

The implementation of maintenance tasks will be consistent with the assigned maintenance in accordance with the following definitions:

a. Inspect. To determine the serviceability of an item by comparing its physical, mechanical, and/or electrical characteristics with established standards through examination.

b. Test. To verify serviceability and to detect incipient failure by measuring the mechanical or electrical characteristics with prescribed standards.

c. Service. Operations required periodically to keep an item in proper operating condition.

(1) Unpack. To remove item from packing box for service or for the performance of other maintenance operations.

(2) Repack. To return item to packing box after service or other maintenance operations.

(3) Clean. To rid the item of contamination.

(4) Touch up. To spot paint scratched or blistered surfaces.

(5) Mark. To restore obliterated identification.

d. Install. To emplace, seat, or fix into position an item in a manner to allow the proper functioning of the equipment; also to assemble one component of an end item with another.

e. Adjust. To maintain within prescribed limits by bringing into proper or exact position, or by setting the operating characteristics to the specified parameters.

f Renovate. To restore item to serviceable condition.

(1) Paint. To repaint the entire item.

(2) Repair. To restore serviceability to an item by correcting specific damage, fault, malfunction, or failure through the application of maintenance services or other maintenance actions,

(3) Replace. To substitute a serviceable component in a manner to allow the proper functioning of equipment.

C-3. SYMBOLS

a. Specific levels of maintenance are indicated by symbols, as follows:

- C - Operator/Crew
- O - Unit
- F - Direct Support
- H - General Support
- D - Depot

b. In the maintenance allocation chart, these symbols reflect the lowest level of maintenance responsible for performing a particular function. Maintenance levels higher than that indicated by the symbol are also authorized to perform the function indicated.

SECTION II. MAINTENANCE ALLOCATION CHART

(1) Group No.	(2) Functional group	(3) Maintenance function											(4) Tools and equipment	(5) Remarks	
		Inspect	Test	Service					Install	Adjust	Renovate				
				Unpack	Repack	Clean	Touch up	Mark			Paint	Repair			Replace
0100	ROCKETS														
0101	Rocket, 2.75-Inch: Assembled complete round, all models Warheads, Fuzed or Unfuzed: All models Fuzes: All models Rocket Motors: All models Packaging Materials	C	D	O	O	C	O	F	O	O	H		O		
		O		O	O	O	O	F	O		H				
		O	D	O	O	O	O	F	O		H				
		O	D	F		O	O	O			O	O	O		
0102	Rocket, 3.5-Inch: Assembled complete round, all models	C	D	C	O	C	O	D	C	D	D	D	D		
0200	LIGHT ANTITANK WEAPON SYSTEMS														
0201	Rocket, HE, 66MM: Antitank, M72 Series Packaging Materials	C	D	C	O	C	O	F			D	D	D		
		O		F		O	O	O				O	O		
0300	ROCKET MOTORS														
0301	Rocket Motor: M3A2E1	C	D	C	O	C	O	D	C	D	D	D	D		

*The 3.5-inch rockets are currently issued to reserve components only. No maintenance other than care and preservation will be performed below depot level.

APPENDIX D

PACKING MATERIALS, ACCESSORIES, AND TOOLS

SECTION I. INTRODUCTION

D-1. SCOPE

This appendix lists packing materials, accessories, and tools required for the performance of organizational maintenance for rockets, rocket motors, and rocket weapon systems.

D-2. GENERAL

This appendix is divided into the following sections:

- a. Section II - Packing Materials and Accessories. A list of packing materials authorized for the performance of maintenance at the organizational level.
- b. Section III - Special Packing Tools. A list of special packing equipment authorized for the performance of maintenance at the organizational level.

D-3. EXPLANATION OF COLUMNS

The following provides an explanation of columns in Section II and III.

- a. Part Number (Drawing Number). Indicates the primary number used by the manufacturer which controls the design and characteristics of the item. Drawings can be obtained from originating source (see CAGE Code).
- b. Contractor and Government Entity Code (CAGE) - (Formerly known as Federal Supply Code for Manufacturers (FSCM)). A five-digit code used to identify the manufacturer, distributor, or Government agency/activity that supplies the item.
- c. Figure Number. This column lists the number of the figure where the item is identified/located.
- d. Description. Indicates the Federal item name and any additional description of the item required.

Section II. PACKING MATERIALS, AND ACCESSORIES

Part No. (Dwg No.)	CAGE Code	Figure No.	Description
9230114	19203		BOX, PACKING, AMMUNITION: w/warheads M151, M156, M230, MK5, WDU-4A/A, WTU-1B
9230116	19203	3-3	BOX, PACKING, AMMUNITION: w/warheads M229, M259, M261, M267
9235841	19203		BOX, PACKING, AMMUNITION: w/warheads M151, M156, and M230
9235840	19203		BOX, PACKING, AMMUNITION: w/warhead M229
8886810	19203		BOX, PACKING, AMMUNITION: M151, M156, M230, MK5, WTU-1/B, M274
9224842	19203		BOX, PACKING, AMMUNITION: M229
9242057 (For CONUS only)	19203		BOX, PACKING, AMMUNITION: WDU-4A/A
8883479	19203		BOX, PACKING, AMMUNITION: MK40
8861213	19203	3-9	BOX, PACKING, AMMUNITION: for rocket fuzes M423, M429, and M435
9340713	19200		BOX, PACKING, AMMUNITION: 4 ea - warhead M274 and motor Mk66
9357963	19200		BOX, PACKING, AMMUNITION: 3 ea - warhead M257 and 3 ea motor Mk66
9242056	19203		BOX, PACKING, AMMUNITION: flechette, WDU-4A/A
8864492	19203	3-9	BOX, AMMUNITION STOWAGE: M423, M429, M435
9230113	19203		CONTAINER, AMMUNITION: fiber, PA30 (warheads M151, M156, M230, WTU-1/B, WDU-4A/A, MK5)
9230115	19203		CONTAINER, AMMUNITION: fiber, PA29 warhead M229
8886811	19203	3-8	CONTAINER, AMMUNITION: fiber, M523, warheads M151, M156, M230, MK5, WTU-1B, M274
9224841	19203		CONTAINER, AMMUNITION: fiber, PA26, warhead HE, M229
9335611	19200		SHIPPING AND STORAGE CONTAINER: fiber, PA89, warhead M261 or M267 and motor Mk66

Part No. (Dwg No.)	CAGE Code	Figure No.	Description
8883478	19203		CONTAINER, AMMUNITION: fiber, M518, MK40, for warhead (M257, WM 2781R)
9335650	19203		CONTAINER, AMMUNITION: metal, PA88 assembly, warheads M151, M261, M264, M267
9335617	19200		CONTAINER, AMMUNITION: fiber, PA87, M66
12934714	19200		CONTAINER, AMMUNITION: fiber, PA145, warhead M229 and motor Mk66
9335614	19203		CONTAINER, AMMUNITION: fiber, PA190, warhead M274 and motor Mk66
8882441	19203		SUPPORT, TOP: for fuze M423
8882442	19203		SUPPORT, BOTTOM: for fuze M423
9217200	19203		SUPPORT, TOP: for fuze M429
9217201	19203		SUPPORT, BOTTOM: for fuze M429
9242106	19203		SUPPORT, TOP: for fuze M432
9242108	19203		SUPPORT, BOTTOM: for fuze M432
			66MM WEAPON SYSTEM
9227926	19203	3-1	BOX, PACKING, AMMUNITION: HE, antitank, M72A1 or M72A2 w/coupler
9227925	19203		BOX, PACKING, AMMUNITION: HE, antitank, M72A1, M72A2, w/coupler
			3.5-INCH ROCKETS
7549038	19203		CONTAINER, AMMUNITION: fiber, M229, M28A2 HEAT, M29A1 practice, M29A2 practice, M30 WP
			ROCKET MOTOR M3A2E1
8835922	19203		BOX, PACKING, AMMUNITION:

Section III. SPECIAL PACKING TOOLS

Part No. (Dwg No.)	CAGE Code	Figure No.	Description
APE 2075M1	19203	3-4	FIXTURE, TORQUE: (NSN 4925-00-781-6511)
66C37709	98747		FUZE, WRENCH, ROCKET: (NSN 4925-00-854-0889)
8864731	19203	3-2	SALLEE CLOSER: (NSN 5120-00-319-5434)
GGG-S-291	81348		SHEARS, METAL CUTTING, HAND: 12 1/2-inch (NSN 5110--00-293-0089)
MILS43104	81349		STRAPPING AND SEALING KIT: (5/8-inch strapping) (NSN 3540-00-565-6242)
MILS43104	81349		STRAPPING AND SEALING KIT: (1 1/4-inch strapping) (NSN 3540-00-565-6244)
YA826-98	332234		WRENCH, STRAP, WHD: (NSN 5120-01-089- 9960) (alternate to NSN 5120-00-020-2947)
2432097	10001		WRENCH, STRAP, WHD: (NSN 5120-00-020- 2947) (alternate to NSN 5120-01-089-9960)

Order of the Secretary of the Army:

GORDON R. SULLIVAN
General, United States Army
Chief of Staff

Official:

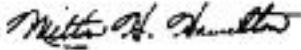

MILTON H. HAMILTON
*Administrative Assistant to the
Secretary of the Army*
07536

Distribution:

To be distributed in accordance with DA Form 12-40E, Block 0529, requirements for TM 9-1340-222-20.

RECOMMENDED CHANGES TO EQUIPMENT TECHNICAL PUBLICATIONS



THEN...JOT DOWN THE DOPE ABOUT IT ON THIS FORM. CAREFULLY TEAR IT OUT, FOLD IT AND DROP IT IN THE MAIL.

SOMETHING WRONG WITH PUBLICATION

FROM: (PRINT YOUR UNIT'S COMPLETE ADDRESS)

DATE SENT

PUBLICATION NUMBER

PUBLICATION DATE

PUBLICATION TITLE

BE EXACT PIN-POINT WHERE IT IS

PAGE NO.

PARA-GRAPH

FIGURE NO.

TABLE NO.

IN THIS SPACE, TELL WHAT IS WRONG AND WHAT SHOULD BE DONE ABOUT IT.

TEAR ALONG PERFORATED LINE

PRINTED NAME, GRADE OR TITLE AND TELEPHONE NUMBER

SIGN HERE

